

ITEM NO.	PART NUMBER	DESCRIPTION	QTY.
1	404125-05	Bioficient Case Assembly - 80m³	1
2	404094-05	Ø2.6 Bioficient 80m³ Recirculation Assembly	1
3	404101	Ø2.6 Bioficient Diffuser Bracket Assembly	5
4	404102-05	2 Diffuser Assembly	1
5	404105-05	8 Diffuser Assembly	2
6	700038	Pump Chamber 4 Float Bracket	1
7	013641	20mm Cable Gland IP55	1
8	015364	Lovato Float Switch	1
9	404152	Ø2.6 Bioficient Loom Mounting Assembly	1
10	006082	19mm Reinforced Hose 440-896 (2m long)	1
11	017950	POLYLOK PL-625 FILTER & HOUSING	2
12	012108	M12 M/S Galvanised Plain Washer	16
13	012615	M12 X 40 Grade 8.8 HTS Galv.Hex Head Bolt	8
14	013152	M12 Galvanised Hex Full Nut	8
15	404281	Ø2.6 BF Airlift Blower, Hoses & Manual Crate	1
16	404287-A	BF 80 BLOWER & PANEL CRATE PALLET	1

NOTE:

- ITEM 10 (006082) TO BE USED AS CABLE SHEATH FOR PUMP CABLE IN BIOZONE
- ITEMS 12, 13 & 14 USED TO FIX FILTER HOUSING TO SIDE OF TURRET (4 FIXINGS PER FILTER)

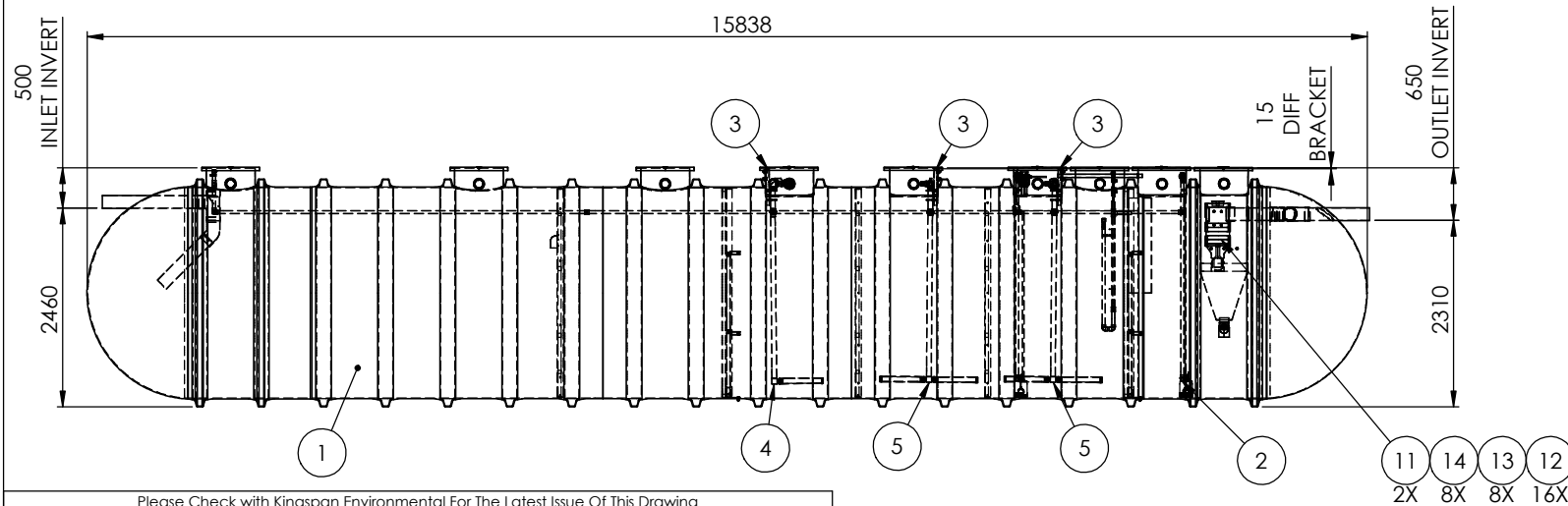
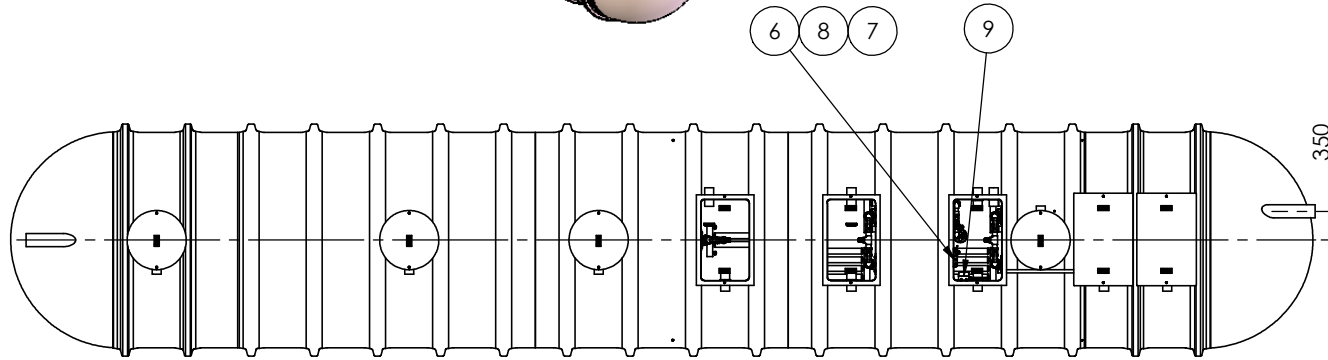
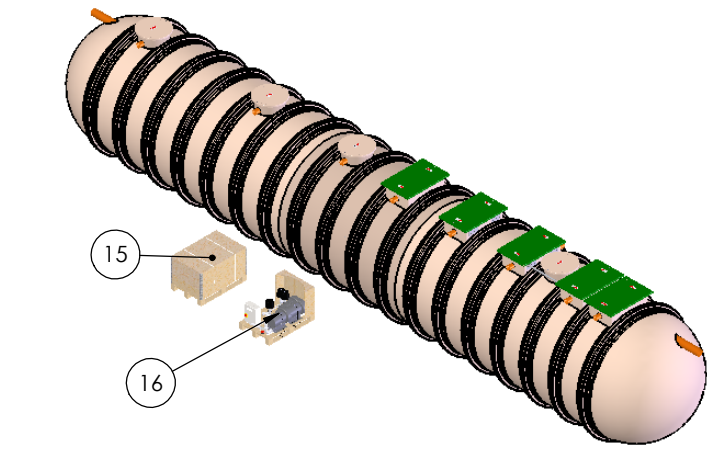

Please Check with Kingspan Environmental For The Latest Issue Of This Drawing

Issue	Date	Drawn by	Approved by	Description
06	28/11/18	W.DYER		CC1456
05	02/02/18	W.DYER		CC1415
04	20/04/17	WMD		CC1374

Material : Various	Tolerance (unless stated) :
Finish :	Thickness : n/a
Weight : 4669.72 Kg	Surface Area : m²
Modelled By : Name	

Drawing : BF80vCwxyz

Page 1 of 4

Bioficient Assembly 80m³

All Dimensions In mm

Scale: Do Not Scale

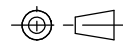

Third Angle Projection

Kingspan Environmental reserve the right to alter the details of this drawing without prior notice. This drawing is copyright and may not be reproduced or used without the written permission of Kingspan Environmental



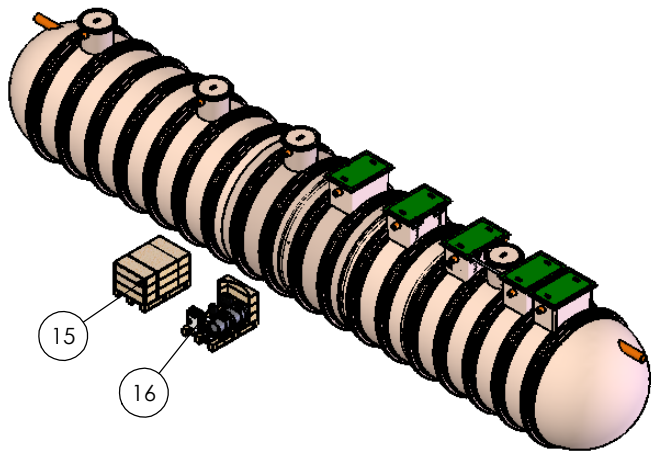

NOTE:
 • ITEM 10 (006082) TO BE USED AS CABLE SHEATH FOR PUMP CABLE IN BIOZONE
 • ITEMS 12, 13 & 14 USED TO FIX FILTER HOUSING TO SIDE OF TURRET (4 FIXINGS PER FILTER)

ITEM NO.	PART NUMBER	DESCRIPTION	08/QTY.
1	404125-08	Bioficient Case Assembly - 80m³	1
2	404094-08	Ø2.6 Bioficient 80m³ Recirculation Assembly	1
3	404101	Ø2.6 Bioficient Diffuser Bracket Assembly	5
4	404102-08	2 Diffuser Assembly	1
5	404105-08	8 Diffuser Assembly	2
6	700038	Pump Chamber 4 Float Bracket	1
7	013641	20mm Cable Gland IP55	1
8	015364	Lovato Float Switch	1
9	404152	Ø2.6 Bioficient Loom Mounting Assembly	1
10	006082	19mm Reinforced Hose 440-896 (2m long)	1
11	017950	POLYLOK PL-625 FILTER & HOUSING	2
12	012108	M12 M/S Galvanised Plain Washer	16
13	012615	M12 X 40 Grade 8.8 HTS Galv.Hex Head Bolt	8
14	013152	M12 Galvanised Hex Full Nut	8
15	404281	Ø2.6 BF Airlift Blower, Hoses & Manual Crate	1
16	404287-A	BF 80 BLOWER & PANEL CRATE PALLET	1

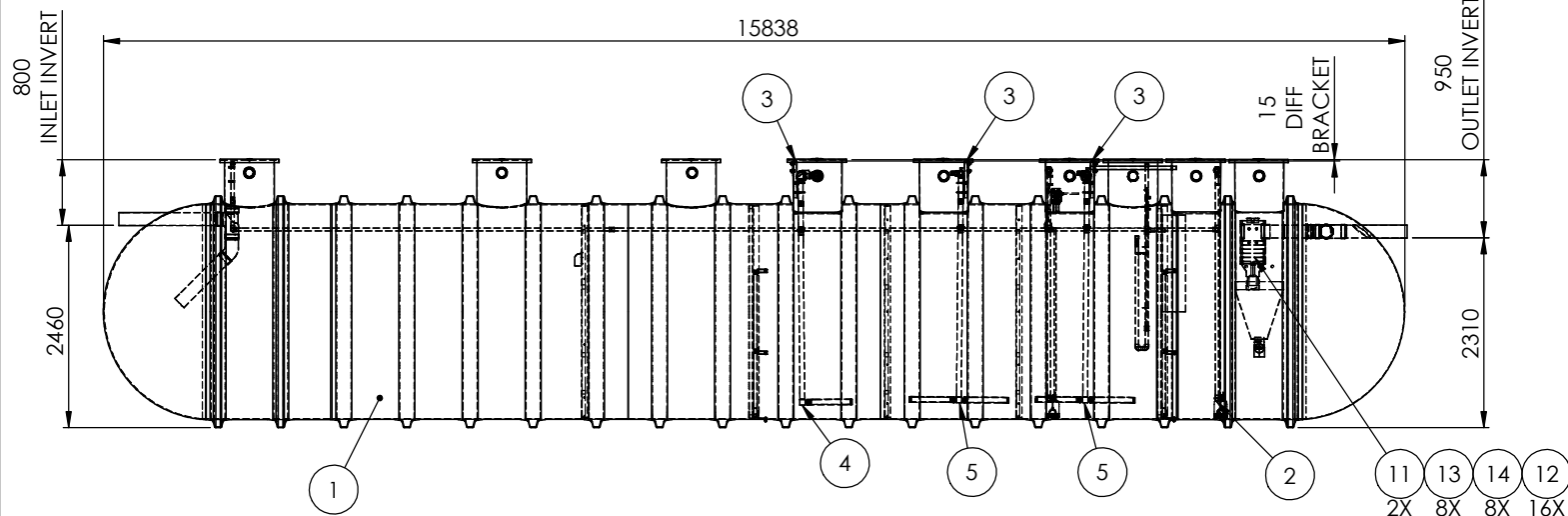
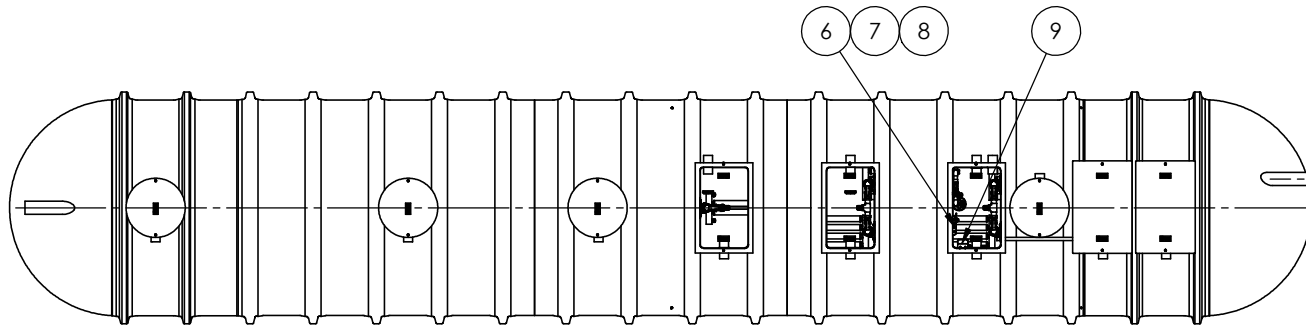

Material : Various	Tolerance (unless stated) :
Finish :	Thickness : n/a
Weight : 4669.72 Kg	Surface Area : m²
Modelled By : Name	

Drawing : BF80vCwxyz Page 2 of 4
 Bioficient Assembly 80m³

All Dimensions In mm

Scale: Do Not Scale

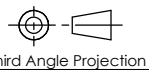

Third Angle Projection

Z:\Drawing Data\01 - Products\Bioficient\Bioficient Commercial 17 - 80\BF80vCwxyz

Kingspan Environmental reserve the right to alter the details of this drawing without prior notice. This drawing is copyright and may not be reproduced or used without the written permission of Kingspan Environmental



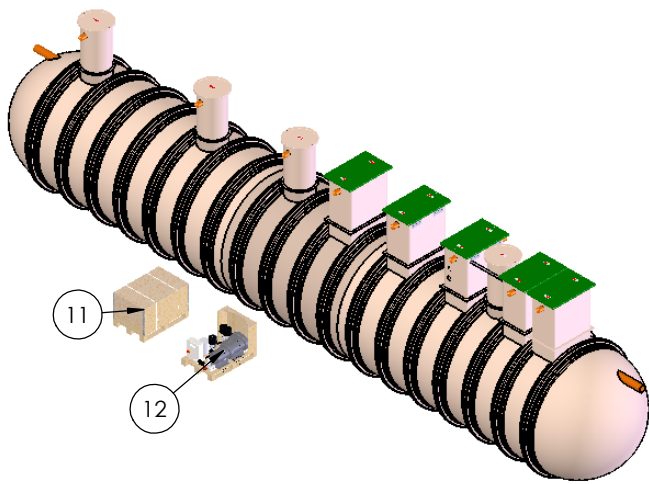

NOTE:

- ITEM 6 (006082) TO BE USED AS CABLE SHEATH FOR PUMP CABLE IN BIOZONE
- ITEMS 8, 9 & 10 USED TO FIX FILTER HOUSING TO SIDE OF TURRET (4 FIXINGS PER FILTER)

ITEM NO.	PART NUMBER	DESCRIPTION	15/QTY.
1	404125-15	Bioficient Case Assembly - 80m³	1
2	404094-15	Ø2.6 Bioficient 80m³ Recirculation Assembly	1
3	404138	1.0m Bioficient Neck Assy 80m³	1
4	404102-15	2 Diffuser Assembly	1
5	404105-15	8 Diffuser Assembly	2
6	006082	19mm Reinforced Hose 440-896 (2m long)	1
7	017950	POLYLOK PL-625 FILTER & HOUSING	2
8	012108	M12 M/S Galvanised Plain Washer	16
9	012615	M12 X 40 Grade 8.8 HTS Galv.Hex Head Bolt	8
10	013152	M12 Galvanised Hex Full Nut	8
11	404281	Ø2.6 BF Airlift Blower, Hoses & Manual Crate	1
12	404287-B	BF 80 BLOWER & PANEL CRATE PALLET	1

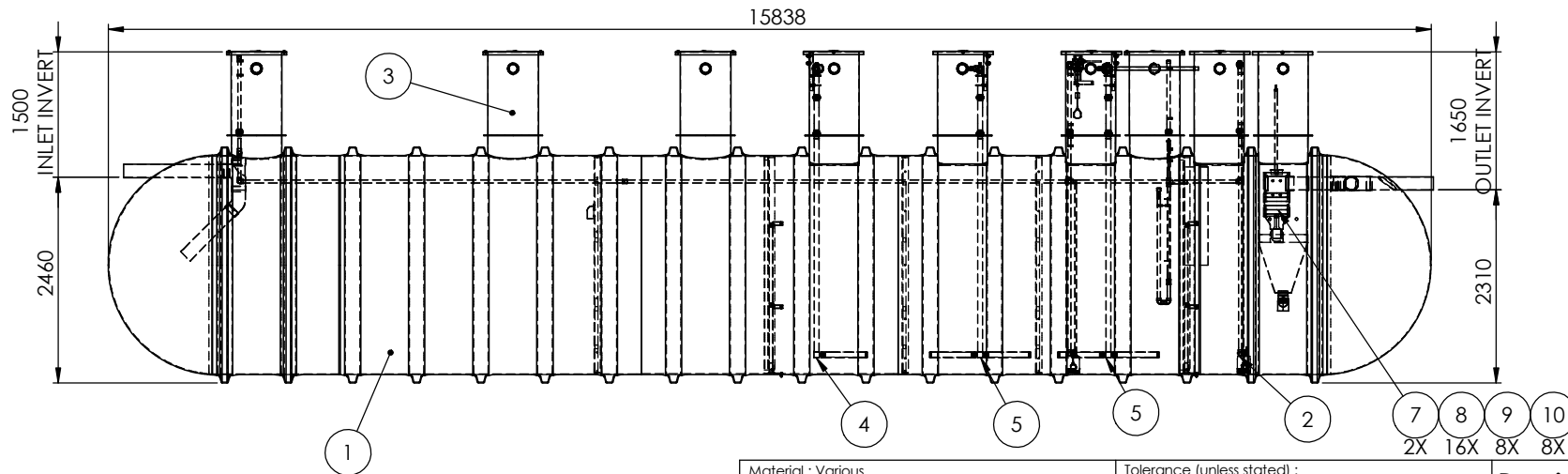
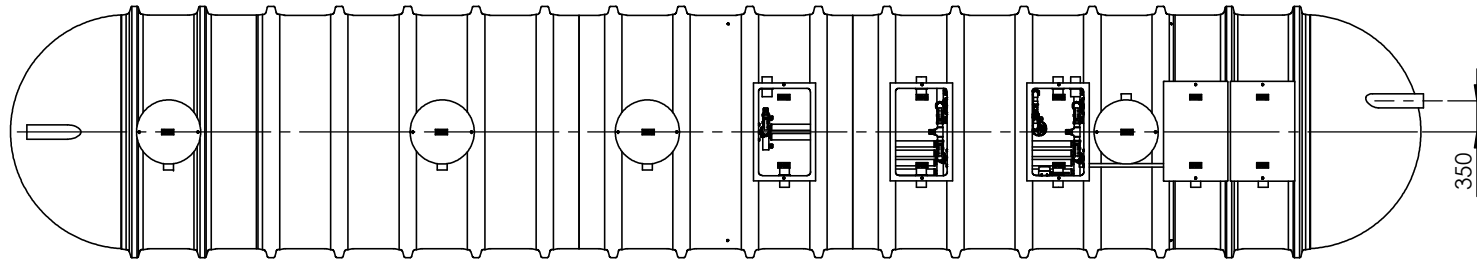

Material : Various	Tolerance (unless stated) :
Finish :	Thickness : n/a
Weight : 4669.72 Kg	Surface Area : m²
Modelled By : Name	

Drawing : BF80vCwxyz

Page 3 of 4

Bioficient Assembly 80m³

All Dimensions In mm

Scale: Do Not Scale

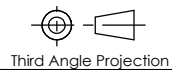

Third Angle Projection

Z:\Drawing Data\01 - Products\Bioficient\Bioficient Commercial 17 - 80\BF80vCwxyz

Kingspan Environmental reserve the right to alter the details of this drawing without prior notice. This drawing is copyright and may not be reproduced or used without the written permission of Kingspan Environmental



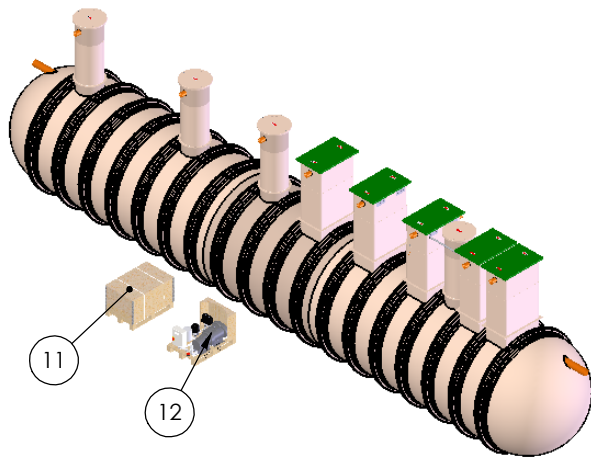

NOTE:

- ITEM 6 (006082) TO BE USED AS CABLE SHEATH FOR PUMP CABLE IN BIOZONE
- ITEMS 8, 9 & 10 USED TO FIX FILTER HOUSING TO SIDE OF TURRET (4 FIXINGS PER FILTER)

ITEM NO.	PART NUMBER	DESCRIPTION	20/QTY.
1	404125-20	Bioficient Case Assembly - 80m³	1
2	404094-20	Ø2.6 Bioficient 80m³ Recirculation Assembly	1
3	404139	1.5m Bioficient Neck Assy 80m³	1
4	404102-20	2 Diffuser Assembly	1
5	404105-20	8 Diffuser Assembly	2
6	006082	19mm Reinforced Hose 440-896 (2m long)	1
7	017950	POLYLOK PL-625 FILTER & HOUSING	2
8	012108	M12 M/S Galvanised Plain Washer	16
9	012615	M12 X 40 Grade 8.8 HTS Galv.Hex Head Bolt	8
10	013152	M12 Galvanised Hex Full Nut	8
11	404281	Ø2.6 BF Airlift Blower, Hoses & Manual Crate	1
12	404287-B	BF 80 BLOWER & PANEL CRATE PALLET	1

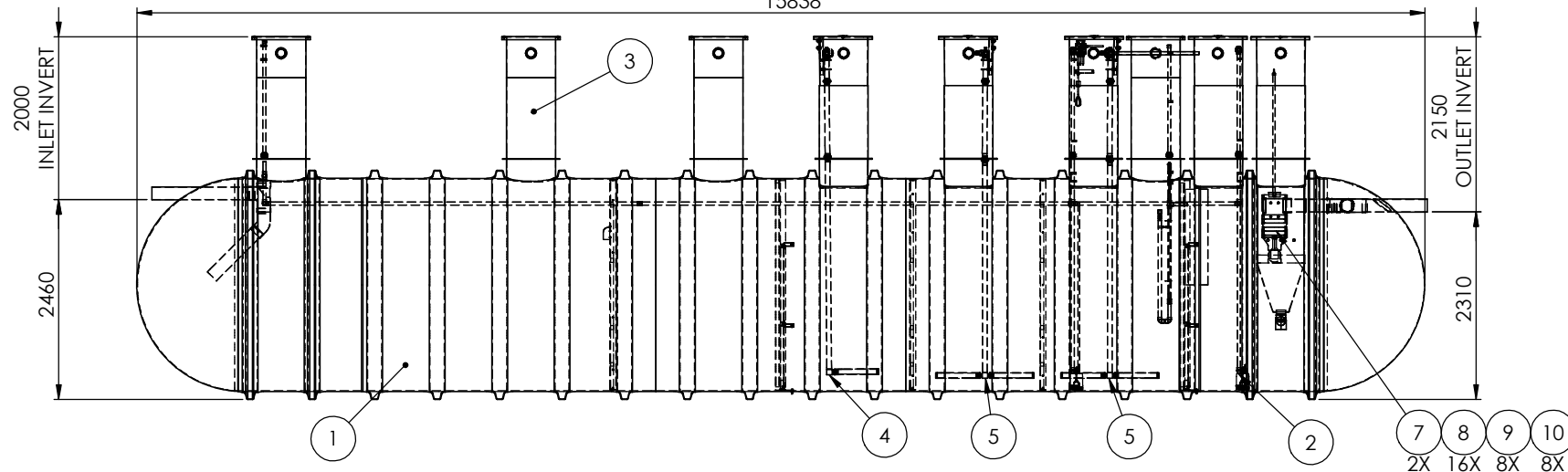
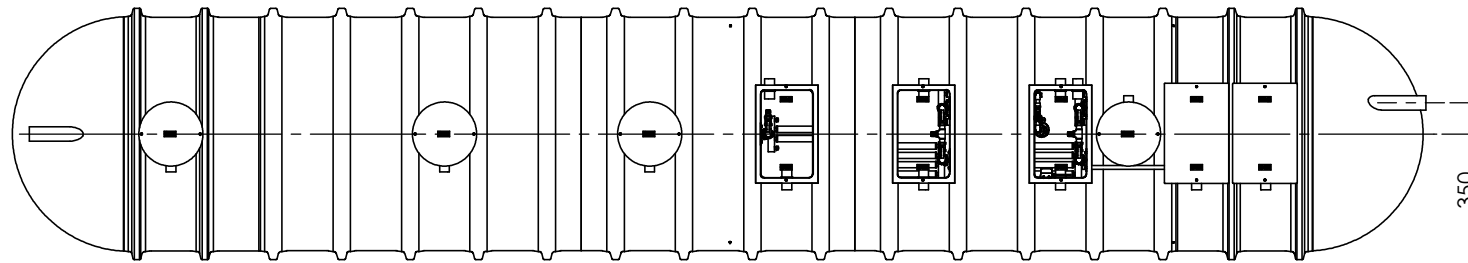

Material : Various	Tolerance (unless stated) :	Drawing : BF80vCwxyz	Page 4 of 4
Finish :	Thickness : n/a		
Weight : 4669.72 Kg	Surface Area : m²	Bioficient Assembly 80m³	
Modelled By : Name			

All Dimensions In mm

Scale: Do Not Scale

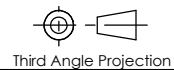

Kingspan Environmental reserve the right to alter the details of this drawing without prior notice. This drawing is copyright and may not be reproduced or used without the written permission of Kingspan Environmental

