

ITEM NO.	PART NUMBER	DESCRIPTION	xx = 05/QTY.
1	404124-05	Bioficient Case Assembly - 67m³	1
2	404093-05	Ø2.6 Bioficient 67m³ Recirculation Assembly	1
3	404101	Ø2.6 Bioficient Diffuser Bracket Assembly	3
4	404102-05	2 Diffuser Assembly	1
5	404104-05	4 Diffuser Assembly	2
6	700038	Pump Chamber 4 Float Bracket	1
7	013641	20mm Cable Gland IP55	1
8	015364	Lovato Float Switch	1
9	404152	Ø2.6 Bioficient Loom Mounting Assembly	1
10	006082	19mm Reinforced Hose 440-896 (2m long)	1
11	017950	POLYLOK PL-625 FILTER & HOUSING	2
12	012108	M12 M/S Galvanised Plain Washer	16
13	012615	M12 X 40 Grade 8.8 HTS Galv.Hex Head Bolt	8
14	013152	M12 Galvanised Hex Full Nut	8
15	404281	Ø2.6 BF Airlift Blower, Hoses & Manual Crate	1
16	404286-A	BF 67 BLOWER & PANEL CRATE PALLET	1

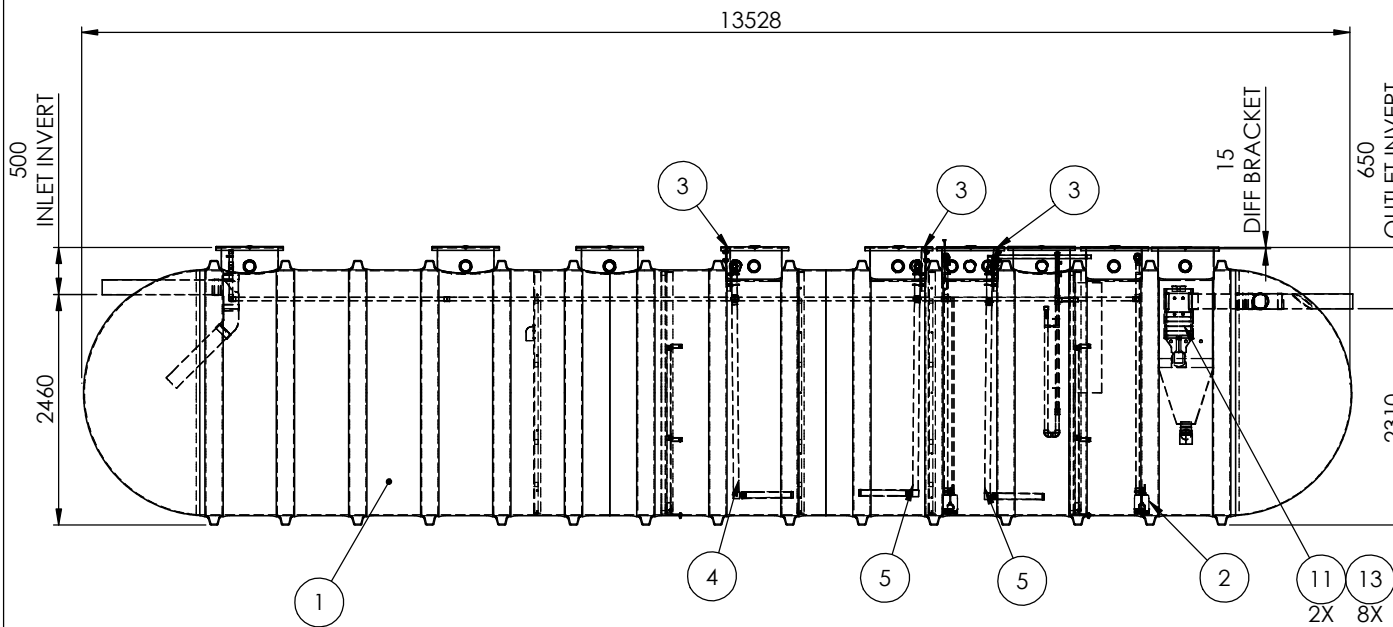

NOTE:

- ITEM 10 (006082) TO BE USED AS CABLE SHEATH FOR PUMP CABLE IN BIOZONE
- ITEMS 12, 13 & 14 USED TO FIX FILTER HOUSING TO SIDE OF TURRET (4 FIXINGS PER FILTER)

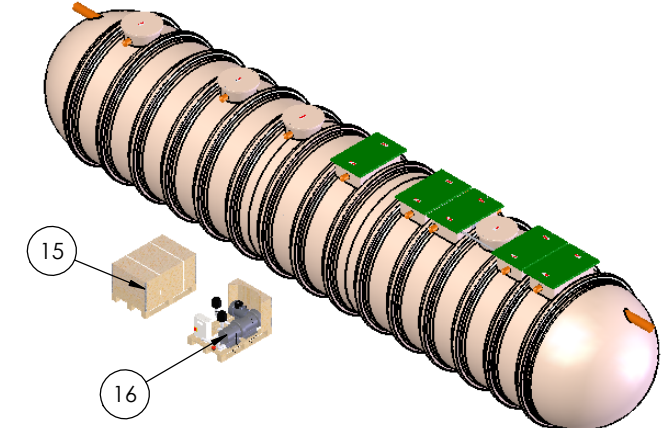

Please Check with Kingspan Environmental For The Latest Issue Of This Drawing

Issue	Date	Drawn by	Approved by	Description
06	28/11/18	W.DYER		CC1456
05	02/02/18	W.DYER		CC1415
04	20/04/17	WMD		CC1374

Material : Various	Tolerance (unless stated) :
Finish :	Thickness : n/a
Weight : 4092.92 Kg	Surface Area : m²
Modelled By : Name	

Drawing : BF67vCwxyz

Page 1 of 4

Bioficient Assembly 67m³

All Dimensions In mm

Scale: Do Not Scale

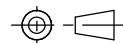

Third Angle Projection

Kingspan Environmental reserve the right to alter the details of this drawing without prior notice. This drawing is copyright and may not be reproduced or used without the written permission of Kingspan Environmental



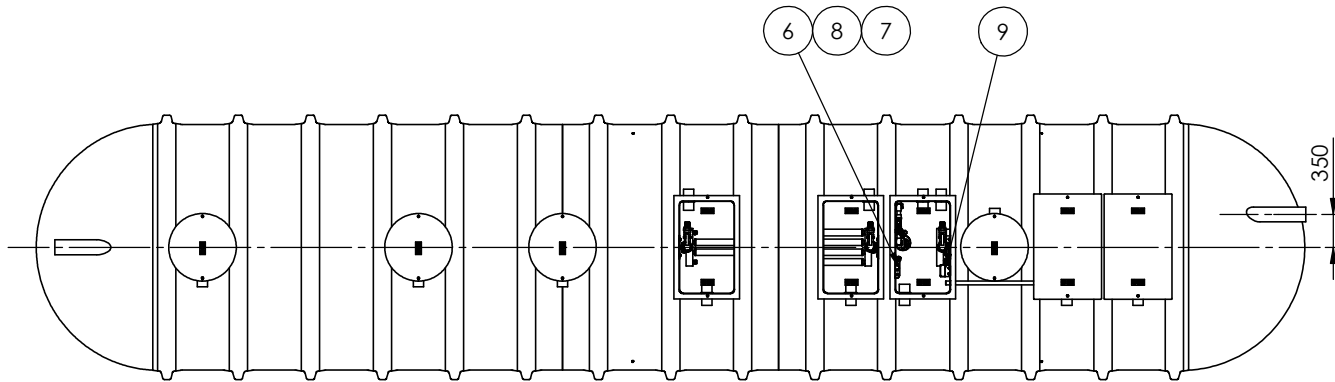

ITEM NO.	PART NUMBER	DESCRIPTION	xx = 08/QTY.
1	404124-08	Bioficient Case Assembly - 67m³	1
2	404093-08	Ø2.6 Bioficient 67m³ Recirculation Assembly	1
3	404101	Ø2.6 Bioficient Diffuser Bracket Assembly	3
4	404102-08	2 Diffuser Assembly	1
5	404104-08	4 Diffuser Assembly	2
6	700038	Pump Chamber 4 Float Bracket	1
7	013641	20mm Cable Gland IP55	1
8	015364	Lovato Float Switch	1
9	404152	Ø2.6 Bioficient Loom Mounting Assembly	1
10	006082	19mm Reinforced Hose 440-896 (2m long)	1
11	017950	POLYLOK PL-625 FILTER & HOUSING	2
12	012108	M12 M/S Galvanised Plain Washer	16
13	012615	M12 X 40 Grade 8.8 HTS Galv.Hex Head Bolt	8
14	013152	M12 Galvanised Hex Full Nut	8
15	404281	Ø2.6 BF Airlift Blower, Hoses & Manual Crate	1
16	404286-A	BF 67 BLOWER & PANEL CRATE PALLET	1

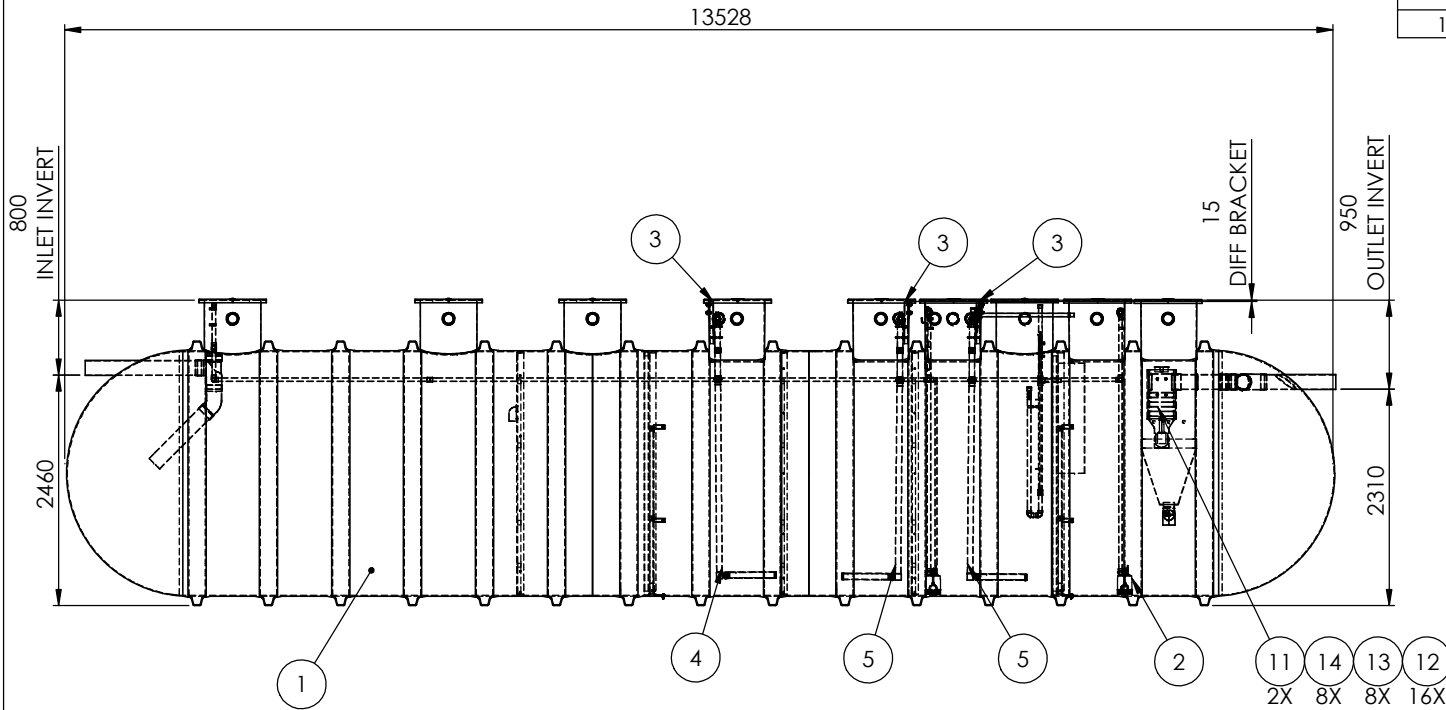

NOTE:

- ITEM 10 (006082) TO BE USED AS CABLE SHEATH FOR PUMP CABLE IN BIOZONE
- ITEMS 12, 13 & 14 USED TO FIX FILTER HOUSING TO SIDE OF TURRET (4 FIXINGS PER FILTER)

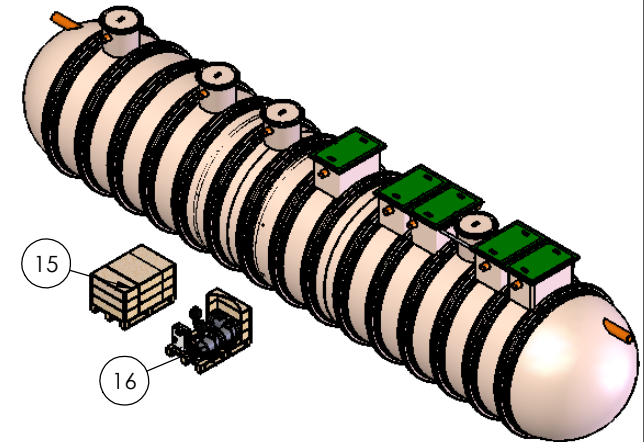

Material : Various	Tolerance (unless stated) :
Finish :	Thickness : n/a
Weight : 4092.92 Kg	Surface Area : m²
Modelled By : Name	

Drawing : BF67vCwxyz Page 2 of 4
Bioficient Assembly 67m³

All Dimensions In mm

Scale: Do Not Scale

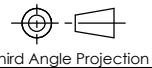

Z:\Drawing Data\01 - Products\Bioficient\Bioficient Commercial 17 - 80\BF67vCwxyz

Kingspan Environmental reserve the right to alter the details of this drawing without prior notice. This drawing is copyright and may not be reproduced or used without the written permission of Kingspan Environmental



ITEM NO.	PART NUMBER	DESCRIPTION	xx = 15/QTY.
1	404124-15	Bioficient Case Assembly - 67m³	1
2	404093-15	Ø2.6 Bioficient 67m³ Recirculation Assembly	1
3	404102-15	2 Diffuser Assembly	1
4	404104-15	4 Diffuser Assembly	2
5	404136	1.0m Bioficient Neck Assy 67m³	1
6	006082	19mm Reinforced Hose 440-896 (2m long)	1
7	017950	POLYLOK PL-625 FILTER & HOUSING	2
8	012108	M12 M/S Galvanised Plain Washer	16
9	012615	M12 X 40 Grade 8.8 HTS Galv. Hex Head Bolt	8
10	013152	M12 Galvanised Hex Full Nut	8
11	404281	Ø2.6 BF Airlift Blower, Hoses & Manual Crate	1
12	404286-B	BF 67 BLOWER & PANEL CRATE PALLET	1

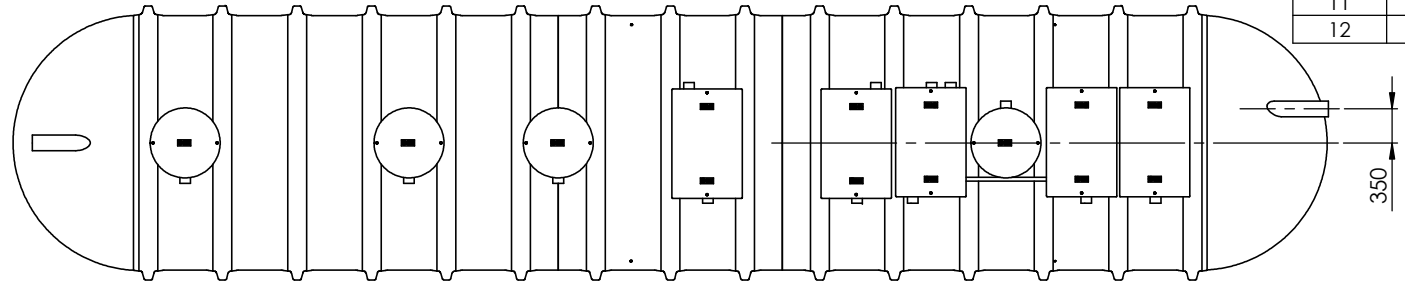

NOTE:

- ITEM 6 (006082) TO BE USED AS CABLE SHEATH FOR PUMP CABLE IN BIOZONE
- ITEMS 8, 9 & 10 USED TO FIX FILTER HOUSING TO SIDE OF TURRET (4 FIXINGS PER FILTER)

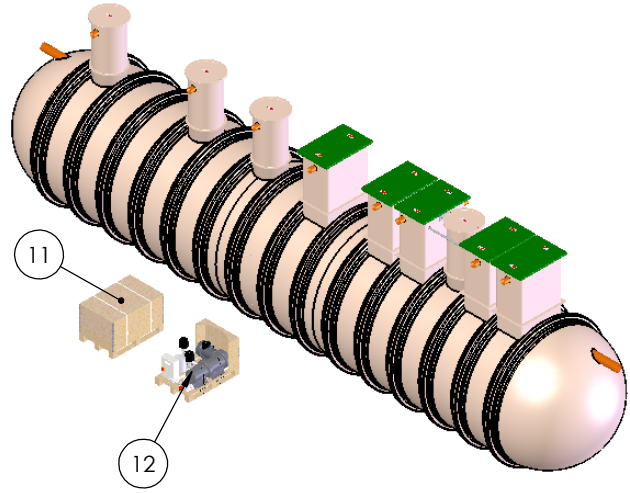
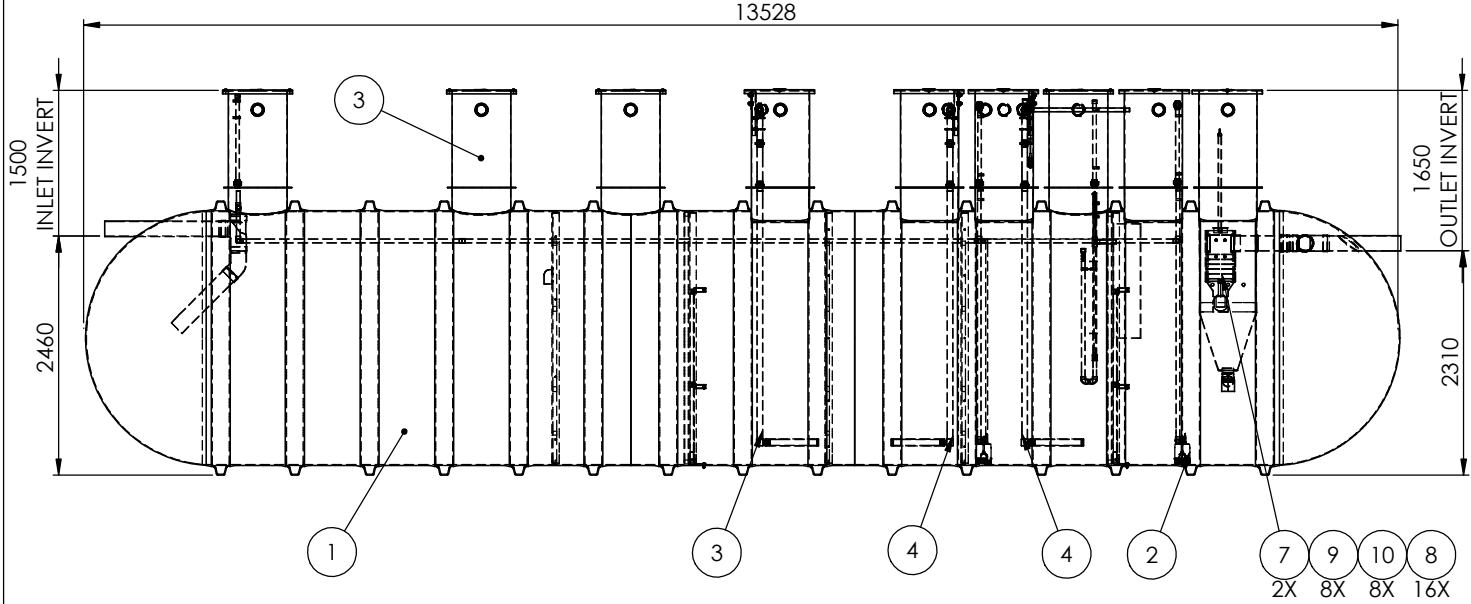

Material : Various	Tolerance (unless stated) :	Drawing : BF67vCwxyz	Page 3 of 4
Finish :	Thickness : n/a		
Weight : 4092.92 Kg	Surface Area : m²		
Modelled By : Name			

All Dimensions In mm Scale: Do Not Scale Third Angle Projection

Z:\Drawing Data\01 - Products\Bioficient\Bioficient Commercial 17 - 80\BF67vCwxyz

Kingspan Environmental reserve the right to alter the details of this drawing without prior notice. This drawing is copyright and may not be reproduced or used without the written permission of Kingspan Environmental



ITEM NO.	PART NUMBER	DESCRIPTION	xx = 20/QTY.
1	404124-20	Bioficient Case Assembly - 67m³	1
2	404093-20	Ø2.6 Bioficient 67m³ Recirculation Assembly	1
3	404102-20	2 Diffuser Assembly	1
4	404104-20	4 Diffuser Assembly	2
5	404137	1.5m Bioficient Neck Assy 67m³	1
6	006082	19mm Reinforced Hose 440-896 (2m long)	1
7	017950	POLYLOK PL-625 FILTER & HOUSING	2
8	012108	M12 M/S Galvanised Plain Washer	16
9	012615	M12 X 40 Grade 8.8 HTS Galv.Hex Head Bolt	8
10	013152	M12 Galvanised Hex Full Nut	8
11	404281	Ø2.6 BF Airlift Blower, Hoses & Manual Crate	1
12	404286-B	BF 67 BLOWER & PANEL CRATE PALLET	1

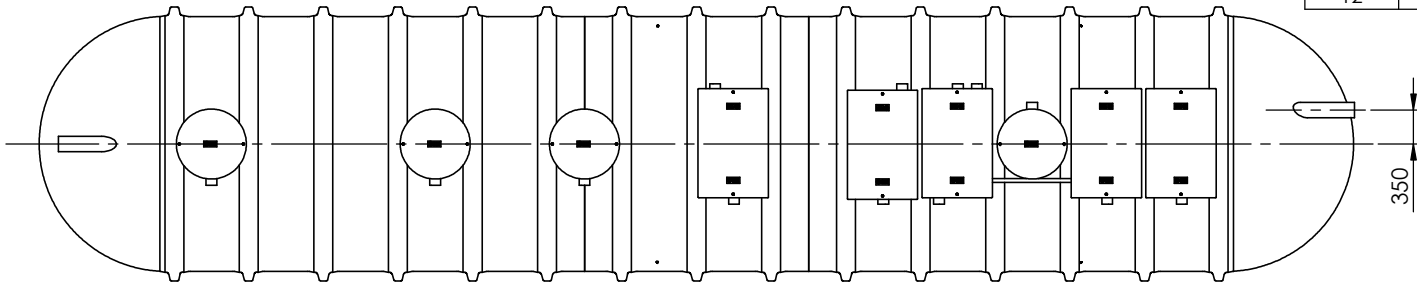

NOTE:

- ITEM 6 (006082) TO BE USED AS CABLE SHEATH FOR PUMP CABLE IN BIOZONE
- ITEMS 8, 9 & 10 USED TO FIX FILTER HOUSING TO SIDE OF TURRET (4 FIXINGS PER FILTER)

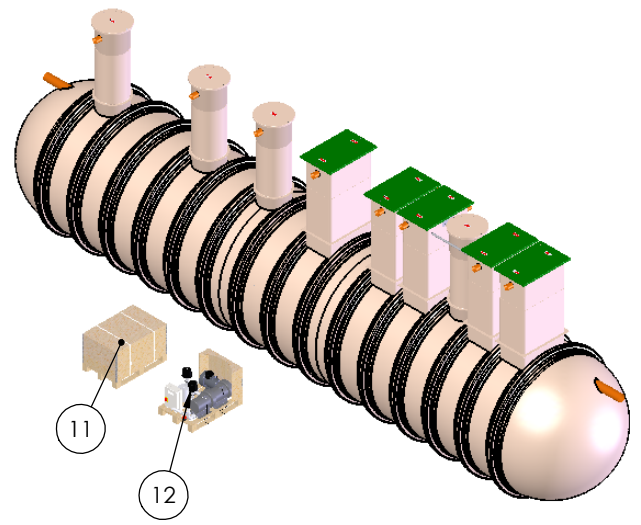
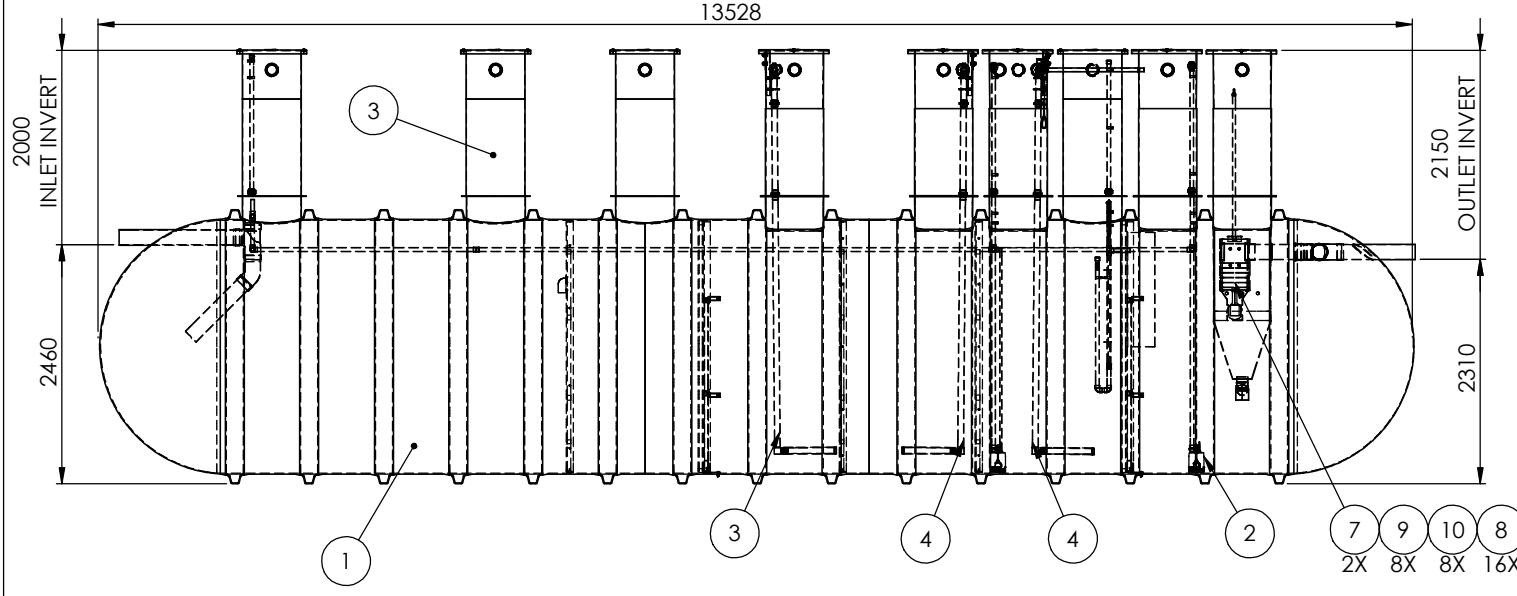

Material : Various	Tolerance (unless stated) :	Drawing : BF67vCwxyz	Page 4 of 4
Finish :	Thickness : n/a		
Weight : 4092.92 Kg	Surface Area : m²		
Modelled By : Name			

All Dimensions In mm Scale: Do Not Scale

Third Angle Projection

Z:\Drawing Data\01 - Products\Bioficient\Bioficient Commercial 17 - 80\BF67vCwxyz

Kingspan Environmental reserve the right to alter the details of this drawing without prior notice. This drawing is copyright and may not be reproduced or used without the written permission of Kingspan Environmental

