

0.5m Invert

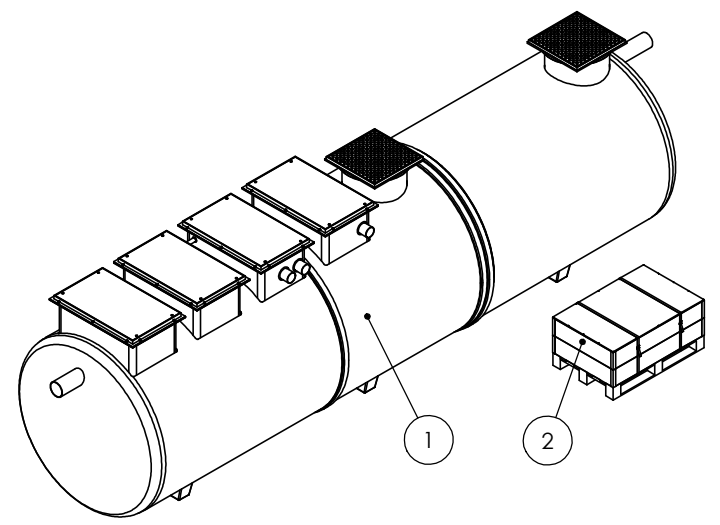

| ITEM NO. | PART NUMBER | DESCRIPTION | 0.5m Invert | 0.5m Invert - No Covers |
|----------|-------------|---|-------------|-------------------------|
| 1 | 404405-05 | Bioficient 17m³ Case Assembly | 1 | - |
| 1 | 404417-05 | Bioficient 17m³ Case Assembly - No Covers | - | 1 |
| 2 | 404268 | Bioficient 17 & 23 Crate Assy - Chemical Dosing | 1 | 1 |

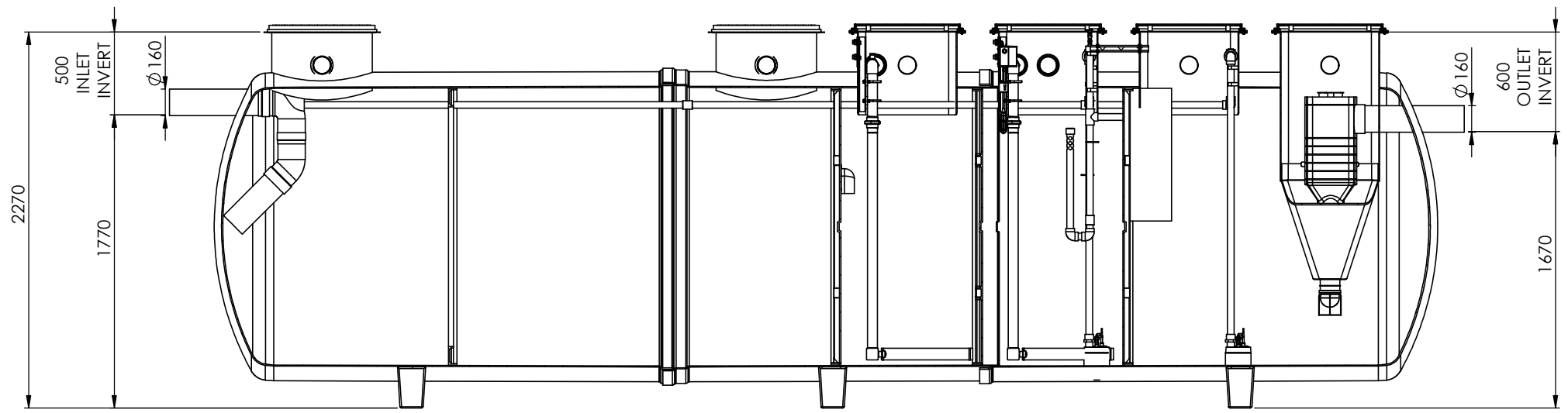

| yy = (Invert) | |
|---------------|------|
| 05 | 0.5m |
| 10 | 1.0m |
| 15 | 1.5m |
| 20 | 2.0m |

| z = (Brand) | |
|-------------|-------------------------|
| B | NSBELABELB (Clearwater) |
| K | NSBELABELK (Klargester) |

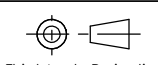

| | | | | | | | |
|--|----------|---------------------|-------------|---|--|---|-------------|
| Please Check with Environmental Treatment Systems Limited For The Latest Issue Of This Drawing | | | | Material : Various | Tolerance (unless stated) : | Drawing : BF17NC2xyy1z | Page 1 of 4 |
| Issue | Date | Drawn by | Approved by | Finish : | Thickness : n/a | | |
| 01 | 05/04/19 | W.DYER | | Weight : 957.90 Kg | Surface Area : m² | Bioficient Assembly 17m³ - Norway | |
| INITIAL ISSUE- CC1481 | | | | Modelled By : T.Kelly | Kingspan Environmental reserve the right to alter the details of this drawing without prior notice. This drawing is copyright and may not be reproduced or used without the written permission of Kingspan Environmental | | |
| All Dimensions In mm | | Scale: Do Not Scale | |  Third Angle Projection | |  | |
| Z:\Drawing Data\01 - Products\Bioficient\Bioficient Commercial 17 - 80\BF17NC2xyy1z | | | | | | | |

1.0m Invert

| ITEM NO. | PART NUMBER | DESCRIPTION | 1.0m Invert | 1.0m Invert - No Covers |
|----------|-------------|---|-------------|-------------------------|
| 1 | 404405-10 | Bioficient 17m³ Case Assembly | 1 | - |
| 1 | 404417-10 | Bioficient 17m³ Case Assembly - No Covers | - | 1 |
| 2 | 404268 | Bioficient 17 & 23 Crate Assy - Chemical Dosing | 1 | 1 |

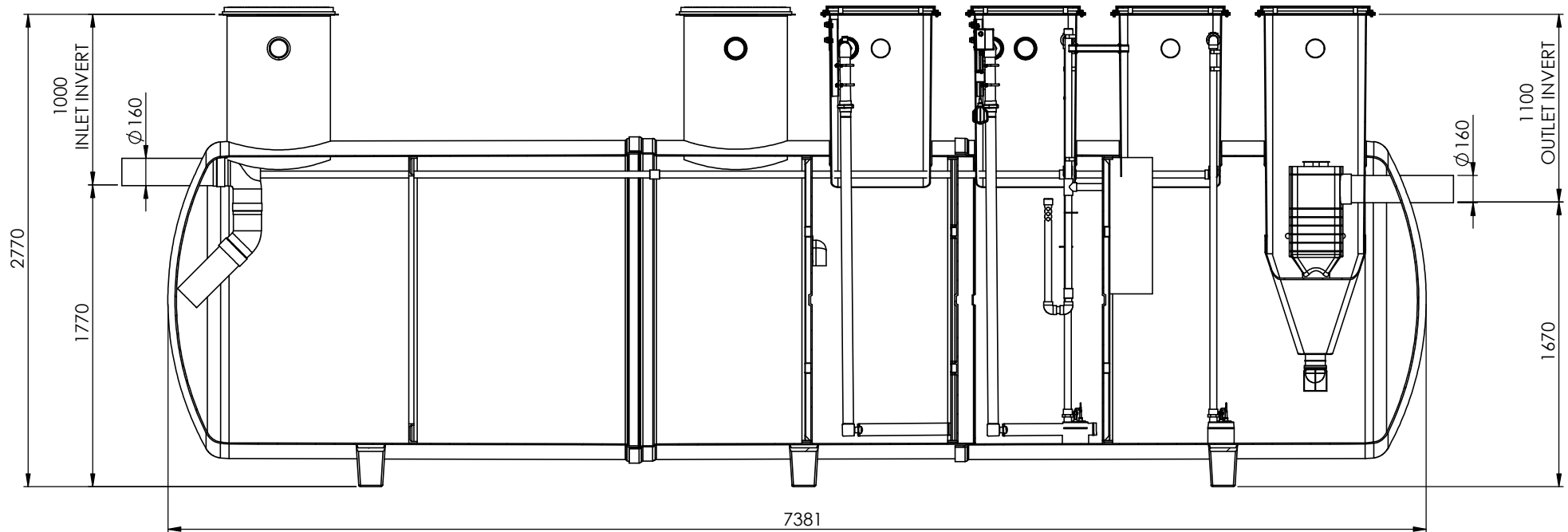
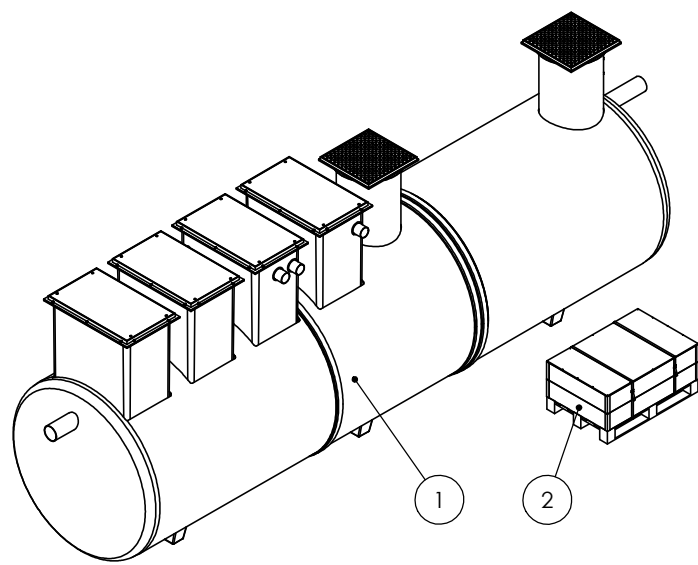

| | | | |
|-----------------------|-----------------------------|-------------------------------|-------------|
| Material : Various | Tolerance (unless stated) : | Drawing : BF17NC2xyy1z | Page 2 of 4 |
| Finish : | Thickness : n/a | | |
| Weight : 957.90 Kg | Surface Area : m² | | |
| Modelled By : T.Kelly | | | |

All Dimensions In mm Scale: Do Not Scale

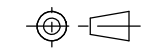

 Third Angle Projection

Z:\Drawing Data\01 - Products\Bioficient\Bioficient Commercial 17 - 80\BF17NC2xyy1z

Kingspan Environmental reserve the right to alter the details of this drawing without prior notice. This drawing is copyright and may not be reproduced or used without the written permission of Kingspan Environmental

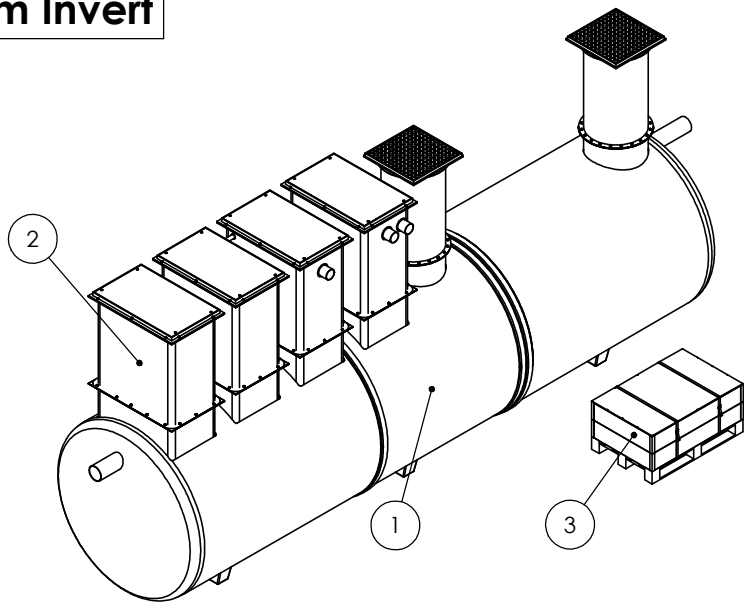

1.5m Invert



| ITEM NO. | PART NUMBER | DESCRIPTION | 1.5m Invert | 1.5m Invert - No Covers |
|----------|-------------|---|-------------|-------------------------|
| 1 | 404405-15 | BioFicient 17m³ Case Assembly | 1 | - |
| 1 | 404417-15 | BioFicient 17m³ Case Assembly - No Covers | - | 1 |
| 2 | 404409 | BioFicient 17 & 23 - Neck Assembly | 1 | - |
| 2 | 404419 | BioFicient 17 & 23 - Neck Assembly No Covers | - | 1 |
| 3 | 404268 | BioFicient 17 & 23 Crate Assy - Chemical Dosing | 1 | 1 |
| 4 | 010264 | TURRET EXTENSION MASTIC KIT | 4 | 4 |
| 5 | 012220 | Mastic & Bolt Assy Kit | 2 | 2 |

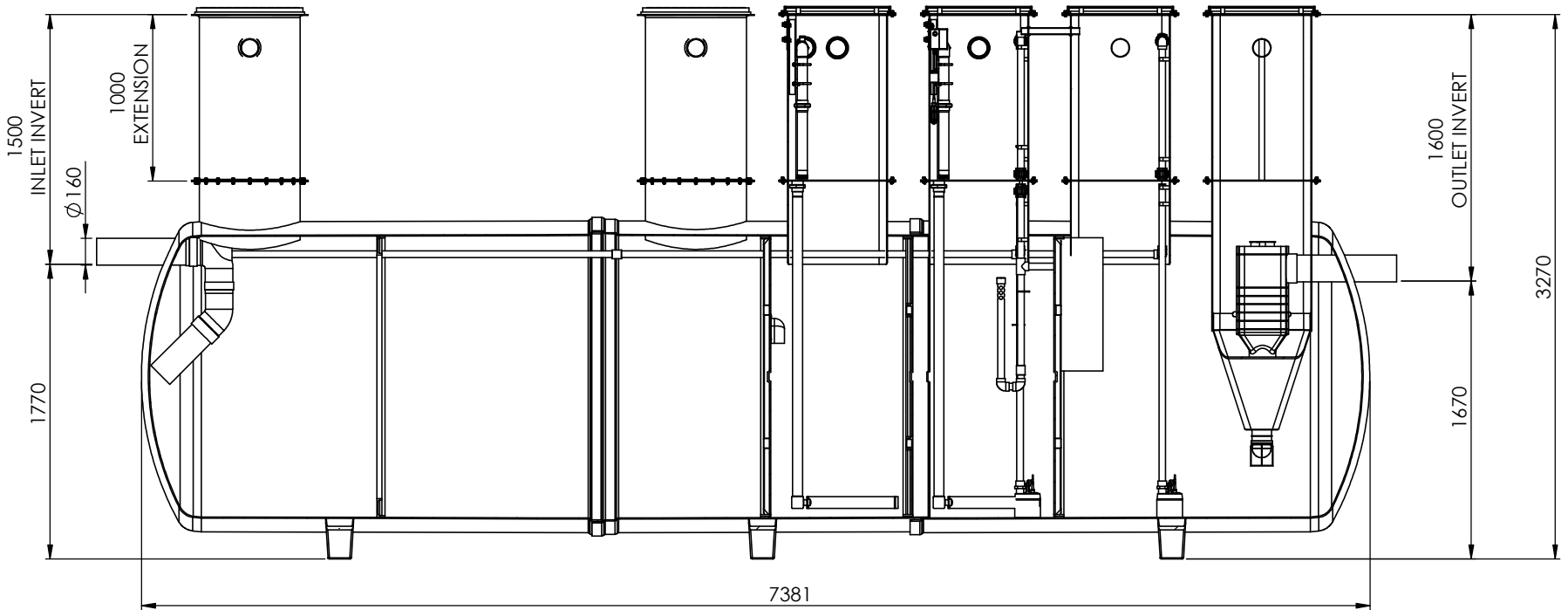

| | | | |
|-----------------------|-----------------------------|-------------------------------|-------------|
| Material : Various | Tolerance (unless stated) : | Drawing : BF17NC2xyy1z | Page 3 of 4 |
| Finish : | Thickness : n/a | | |
| Weight : 957.90 Kg | Surface Area : m² | | |
| Modelled By : T.Kelly | | | |

| | | |
|---|---------------------|---|
| All Dimensions In mm | Scale: Do Not Scale |  Third Angle Projection |
| Z:\Drawing Data\01 - Products\BioFicient\BioFicient Commercial 17 - 80\BF17NC2xyy1z | | |

Kingspan Environmental reserve the right to alter the details of this drawing without prior notice. This drawing is copyright and may not be reproduced or used without the written permission of Kingspan Environmental



2.0m Invert

| ITEM NO. | PART NUMBER | DESCRIPTION | 2.0m Invert | 2.0m Invert - No Covers |
|----------|-------------|---|-------------|-------------------------|
| 1 | 404405-20 | BioFicient 17m³ Case Assembly | 1 | - |
| 1 | 404417-20 | BioFicient 17m³ Case Assembly - No Covers | - | 1 |
| 2 | 404409 | BioFicient 17 & 23 - Neck Assembly | 1 | - |
| 2 | 404419 | BioFicient 17 & 23 - Neck Assembly No Covers | - | 1 |
| 3 | 404268 | BioFicient 17 & 23 Crate Assy - Chemical Dosing | 1 | 1 |
| 4 | 010264 | TURRET EXTENSION MASTIC KIT | 4 | 4 |
| 5 | 012220 | Mastic & Bolt Assy Kit | 2 | 2 |

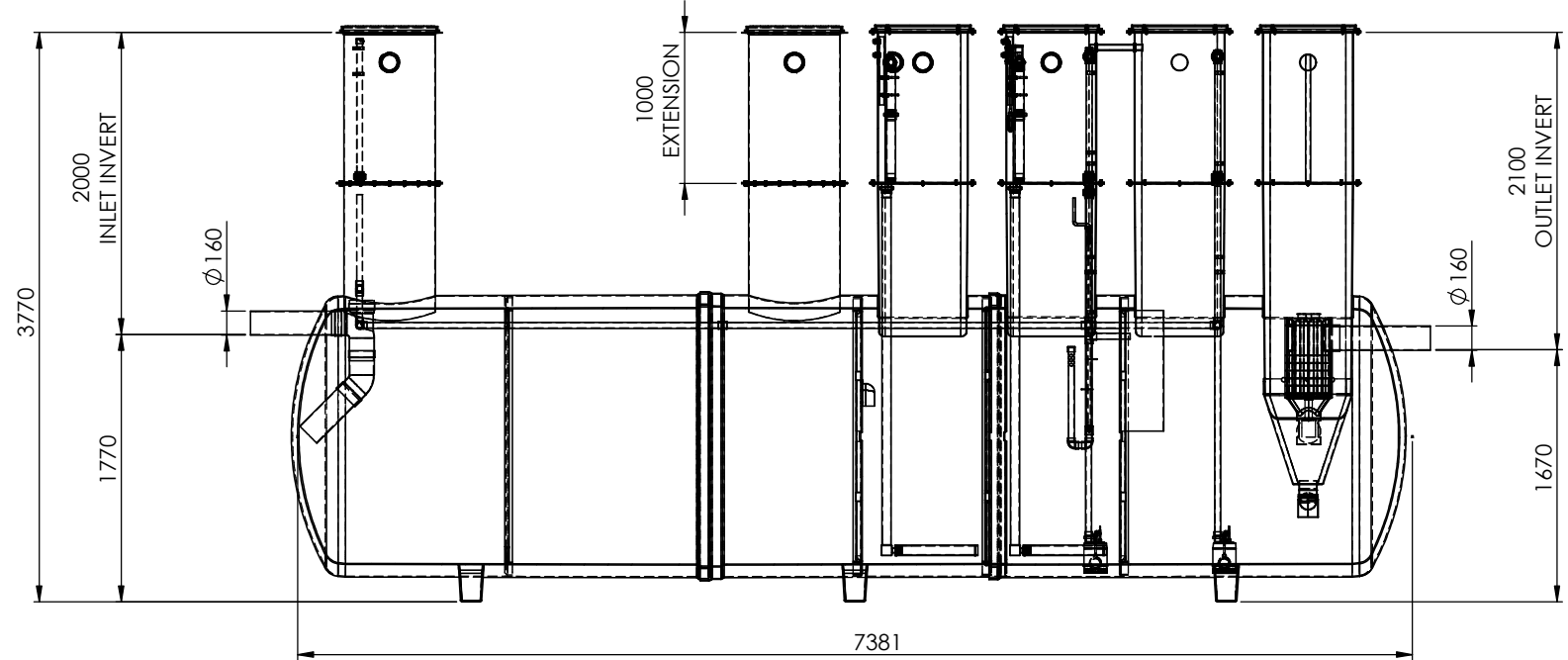
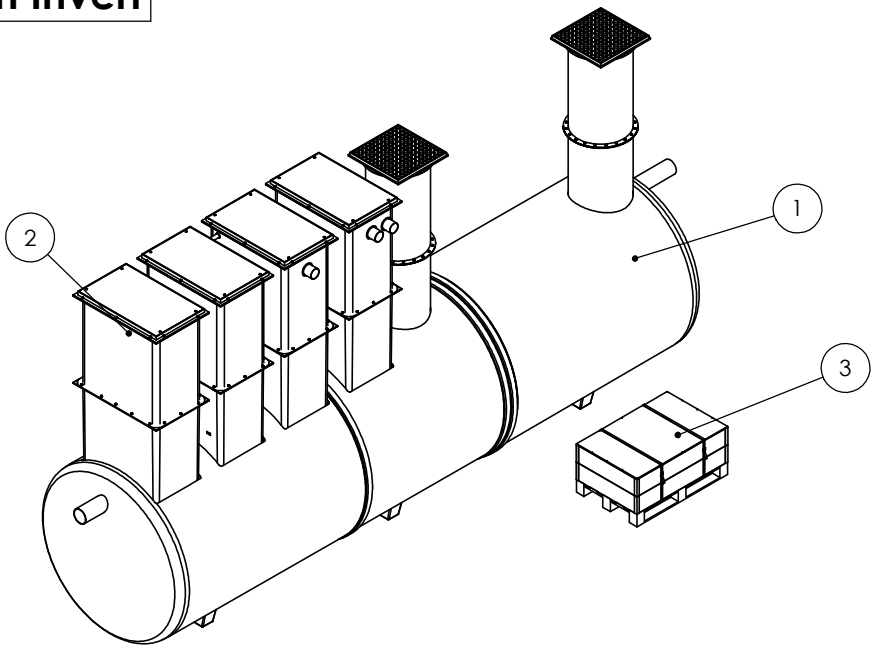

| | | | |
|-----------------------|-----------------------------|-----------------------------------|-------------|
| Material : Various | Tolerance (unless stated) : | Drawing : BF17NC2xyy1z | Page 4 of 4 |
| Finish : | Thickness : n/a | | |
| Weight : 957.90 Kg | Surface Area : m² | BioFicient Assembly 17m³ - Norway | |
| Modelled By : T.Kelly | | | |

All Dimensions In mm Scale: Do Not Scale

Third Angle Projection

Z:\Drawing Data\01 - Products\BioFicient\BioFicient Commercial 17 - 80\BF17NC2xyy1z

Kingspan Environmental reserve the right to alter the details of this drawing without prior notice. This drawing is copyright and may not be reproduced or used without the written permission of Kingspan Environmental

