

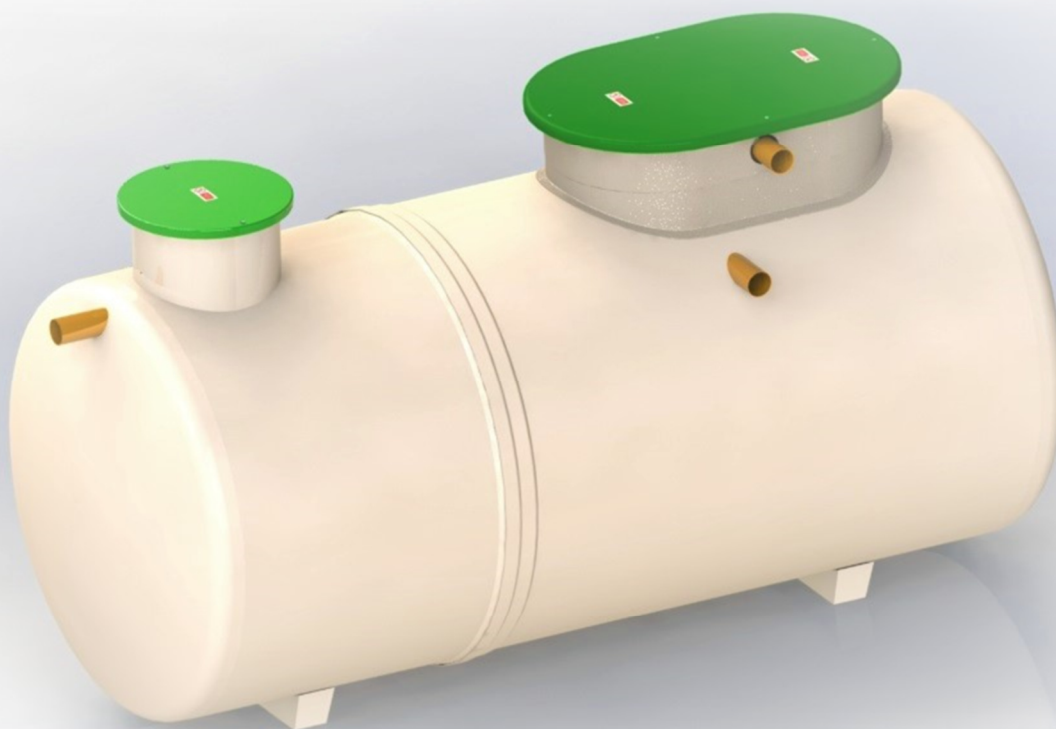

BioFicient 4-6 Klargester – Sewage Treatment Plant

INSTALLATION MANUAL



Part Code	Issue	Description	Date
017904	03	CC1437	May 2018

Contents

Health and Safety	Page 3
Desludging	Page 4
Self Help	Page 5
System Overview	Page 6
BioFicient Checklist	Page 7
Installation	Page 8
BioFicient® IPS HLA	Page 12
Control Panel Installation	Page 13
Start up	Page 17



HEALTH AND SAFETY

You must read these warnings carefully before installing or using the equipment. Always ensure that all relevant documents are supplied with the equipment transferred to a new owner. Observe all hazard labels and take appropriate action to avoid exposure to the risks indicated. Take care to maintain correct posture, particularly when lifting. Use appropriate lifting equipment when necessary.



- Only experienced contractors should carry out installation, following the guidelines.
- The unit should have a Pre-Service Agreement Inspection by an approved engineer.
- A qualified electrician should carry out electrical work.
- Covers must be kept locked.
- Observe all hazard labels and take appropriate action to avoid exposure to the risks indicated.

CLOTHING

- We recommend the use of a dust mask and gloves when cutting GRP components.
- Any person carrying out maintenance on the equipment should wear suitable protective clothing, including gloves.



MAINTENANCE AND INSPECTION PROCEDURES

- If you wish to inspect the operation of the equipment, please observe all necessary precautions, including those listed below, which apply to maintenance procedures.
- The power supply to the equipment must be isolated at the control panel(s) before lifting the covers.
- If the equipment should run with the covers off, all care must be taken to avoid contact with moving parts and electrical components or conductors.
- Once power has been isolated, the control panel must be kept locked shut to avoid accidental re-connection whilst work or inspection is being carried out.

WORKING AREA

- Ensure that the working area is adequately lit.
- Ensure that you are familiar with the safe working areas and accesses.
- Use only the designated access walkways. Do not walk on the cover or deep well safety mesh.
- Always keep proper footing and balance to avoid any sharp edges.

DESLUDGING

Desludging should be carried out by a licensed waste disposal contractor holding the relevant permits to transport and dispose of sewage sludge.

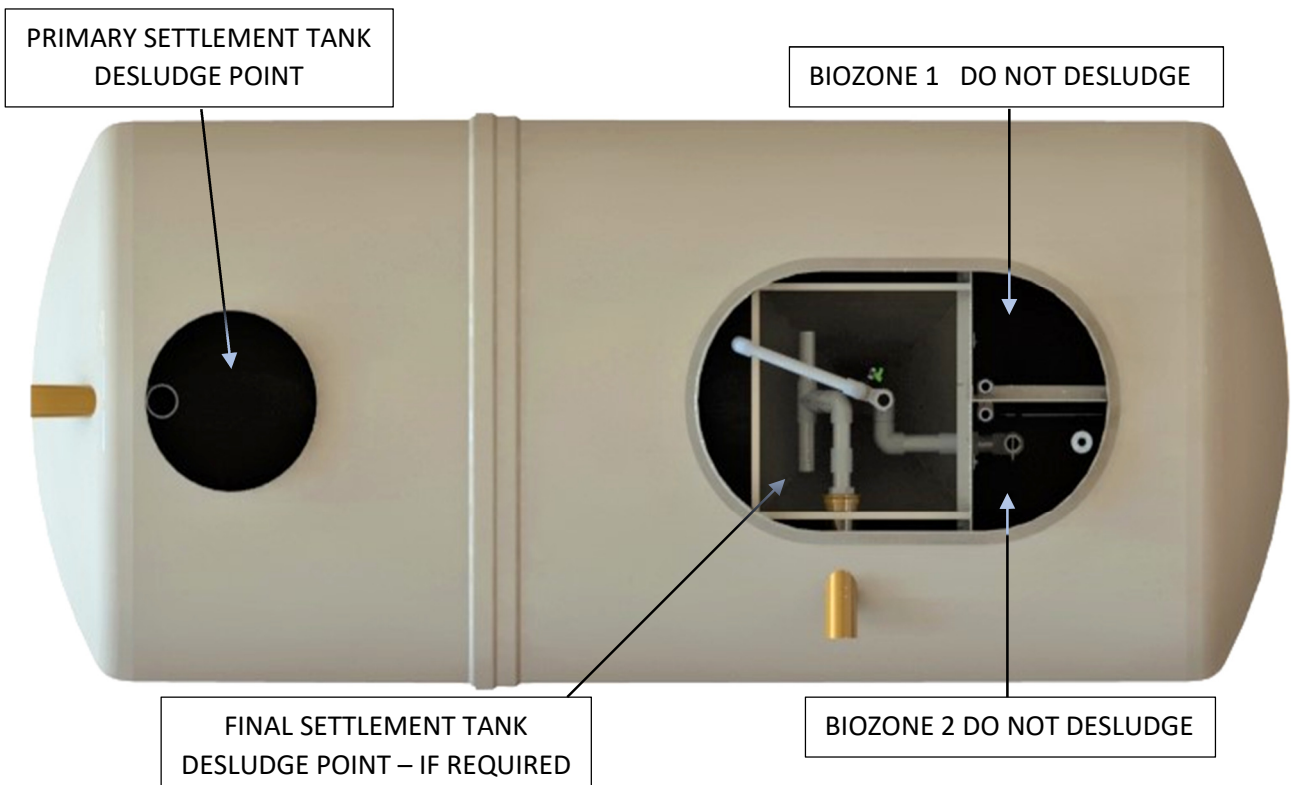

Desludge Volumes

Model	BFG 4	BFG 5	BFG 6
Primary Settlement Tank	4700 Litres (1040 gal)	6400 Litres (1420 gal)	12300 Litres (2730 gal)
Final Settlement Tank	135 Litres (30 gal)	180 Litres (40 gal)	270 Litres (60 gal)
Desludge Period	9 Months Maximum	9 Months Maximum	9 Months Maximum

SELF HELP

To minimize the need for dealing with emergency situations we recommend that Sewage Treatment Plants have a Pre-service. Agreement Inspection, and then is regularly serviced by us or an approved Service Engineers. Provided that your plant is installed, operated correctly and serviced, you should not need to get into much – if any – self-help. However, some of the most likely question and answer situations are listed below.

Blower Failure

Blower Stopped:

- Check the unit is switched on, the incoming power supply circuit and fuse.

Blower works but no water distribution inside the plant:

- Check hose connections.
- Check distributor heads.
- If the air lift pipes are suspected to be blocked, call for service which number and other details you can find on the back page of this manual.
- Check regulating valve is not closed.



Bioficient 4-5 External Blower

Plant flooding

- Check for blocked outlet system.
- If pumped outlet is all right, check for pump operation, check floats and pump power supply.

Plant odour

- Check blower working. If blower working, plant probably needs desludging.
- Check vent circuit is clear.
- Check that the air duct entering the blower housing has been sealed with foam.

DO's



Do take out a service agreement and let the experts look after your plant.

Do contact us for advice if you have any cause for concern. All contact details are at the end of this manual.

DON'TS



Don't pump feed the plant without seeking advice from Kingspan or installer.

Don't use a waste disposal unit as you will be adding to the biological load, and your system may not be large enough to cope with the waste. If you are unsure please refer to our sales team for guidance.

Don't throw any medicines down the toilet.

Don't empty large quantities of bleach or similar cleaning reagents into the system.

Don't empty cooking oil or similar down the sink.

Don't cover the plant with soil material or prevent access for service and desludging.

Don't apply a hose or jet wash to the biological filter unless specifically advised to do so.

Don't try to enter the plant.

Don't put sanitary towels, incontinence pads, nappies, tampons or other non-biodegradable items' down the toilet.



Bioficient 6 External Blower

SYSTEM OVERVIEW

Pictorial representation below indicates basic requirements for a standard system, please note that not all the items required are supplied by Kingspan.



*BLOWER HOUSING Bioficient 6 ONLY

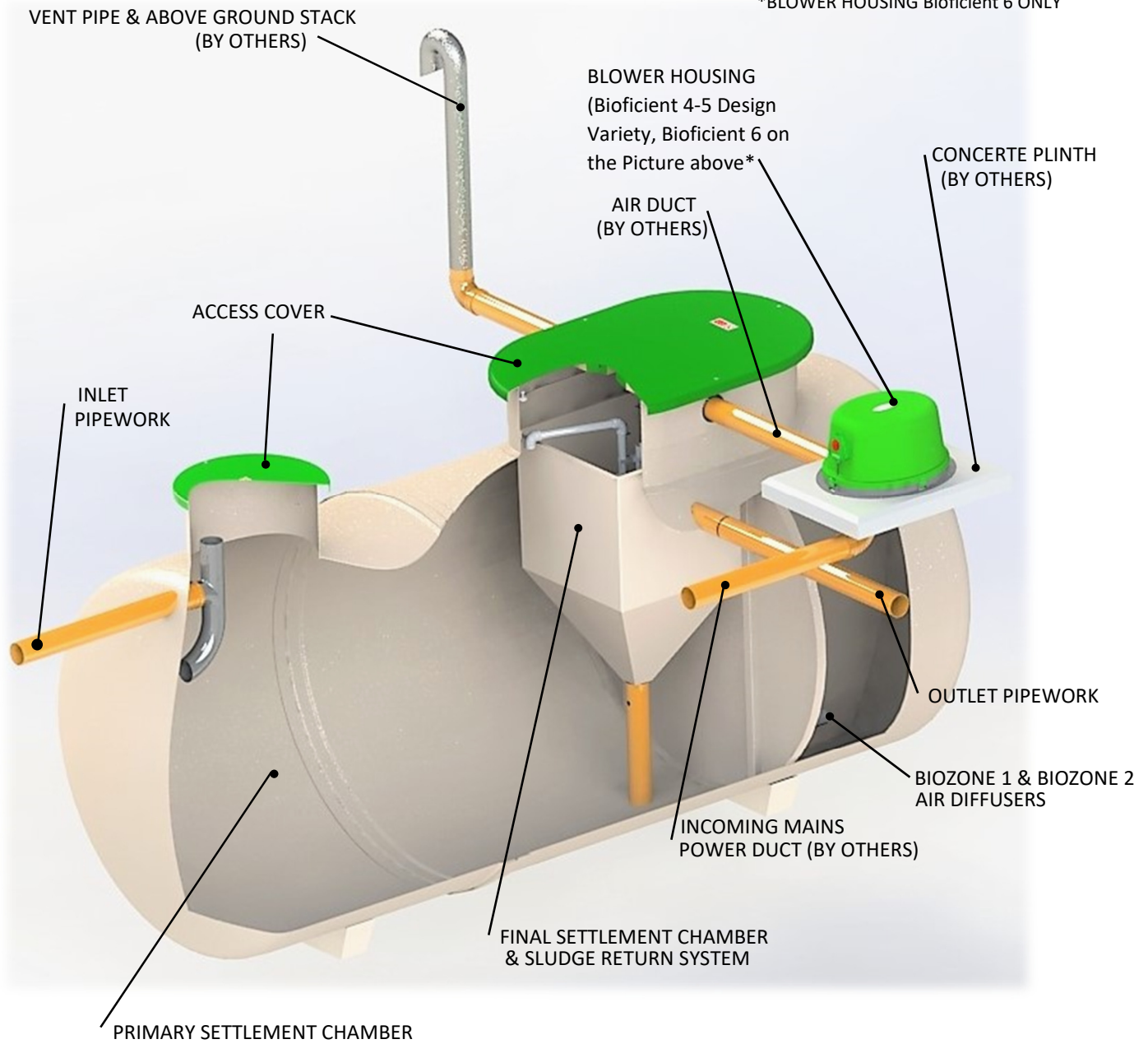

BioFicient® CHECKLIST

The delivery paperwork will have 2 no. items listed; check that the Tank Code (Item 1) & Blower Assembly Code (Item 2) are the same as the codes on the units delivered.

Example;

Top Level Product Code – BFGAG050K

Item 1 – BFPTANK4GO50K (Tank Code)

Item 2 - BHBF4GOK (Blower Assembly Code)

Sewage Treatment Tank

Item 1

NB: Storage tanks vary in design and volume (15PE to 30PE). Please check your order and cross reference with relevant sales drawing.



Blower Housing Assembly

Item 2

The Blower Assembly consists of the Blower Unit, Control Panel or Isolator, and associated pipework and fittings.

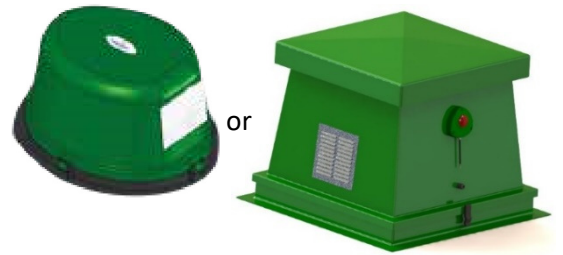

13 mm Hose Coil - 15 Metres

13 mm Hose required to connect from 1/2" Hose Connector in Blower Housing to Sludge-return Pipework located with the Tank (Supplied inside Blower Housing Packaging).



19 mm Hose Coil - 15 Metres

19 mm Hose required to connect from 3/4" Hose Connector in Blower Housing to Air Diffuser Manifold located with the Tank (Supplied inside Blower Housing Packaging).



INSTALLATION

1. EXCAVATE A HOLE & LAY CONCRETE BED

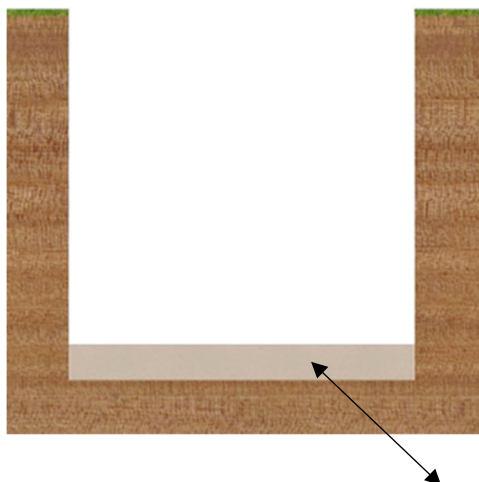

Approximate dimensions

Model	Diameter /Width (mm)	Length (mm)	Inlet Invert (mm)	Outlet invert (mm)	Installation depth* (mm)
Bioficient 4	1920	3230	500	630	2300
Bioficient 5	1920	4390	500	630	2300
Bioficient 6	1920	6220	500	630	2300

* Based on 500 mm invert

- For DRY CONDITIONS excavate a hole to appropriate depth allowing minimum clearance on all sides and base of the unit of 200mm and level the base.
- For WET CONDITIONS excavate a hole at least 300mm deeper than the tank, for lean mix concrete and hard-core base. Allow for tank width plus at least 400mm with additional allowance for any necessary shuttering. De-water the excavation using suitable pumping equipment. Ensure that the pump discharge does not saturate the ground in the immediate vicinity. The installer should ensure that the base is adequate to support the weight of the tank and its contents. Place a sheet of polythene over the hard-core and up the sides of the excavation before putting in the concrete cradle.
- For UNSTABLE BASE of the excavation, i.e. running sand or similar, excavate an additional 250-300mm below concrete levels and fill up with compacted hard-core.
- A base of at least 150 - 200mm of lean mix concrete should be provided. (FOR CONCRETE SPEC. SEE BELOW).
- It is recommended to back fill with C25 SEMI-DRY MIX

GENERAL CONCRETE SPECIFICATION IN ACCORDANCE WITH BS EN 206-1 (BS 8500-1)

TYPE OF MIX		(DC) DESIGN
PERMITTED TYPE OF CEMENT		BS 12 (OPC): BS 12 (RHPC): BS 4027 (SRPC)
PERMITTED TYPE OF AGGREGATE (coarse & fine)		BS 882
NOMINAL MAXIMUM SIZE OF AGGREGATE		20 mm
GRADES:	C25 /30 C25 /30 C16 /20	REINFORCED & ABOVE GROUND WITH HOLDING DOWN BOLTS REINFORCED (EG. FOR HIGH WATER TABLE) UNREINFORCED (NORMAL CONDITIONS)
MINIMUM CEMENT CONTENT	C30 C20	270 - 280 Kg/M ³ 220 - 230 Kg/M ³
SLUMP CLASS		S1 (25mm)
RATE OF SAMPLING		READY MIX CONCRETE SHOULD BE SUPPLIED COMPLETE WITH APPROPRIATE DELIVERY TICKET IN ACCORDANCE WITH BS EN 12350-1
NOTE: STANDARD MIXES SHOULD NOT BE USED WHERE SULPHATES OR OTHER AGGRESSIVE CHEMICALS EXIST IN GROUND WATER		

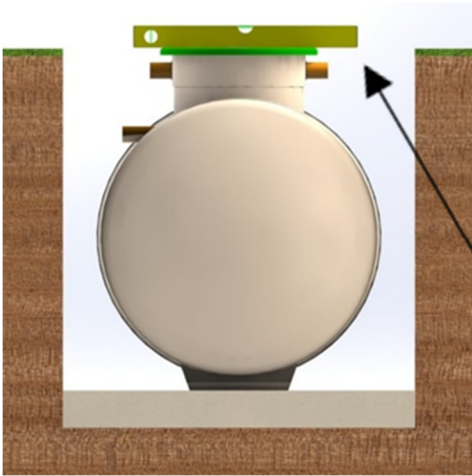

2. LOWER UNIT ONTO CONCRETE & ENSURE LEVEL

- Lower the tank in the hole using a sling through the lifting points provided on the tank.
- Under no circumstances should the sling be attached to the inlet pipe or the outlet pipe.
- Tank should not be lifted with any water inside.
- Check that the **Inlet** and **Outlet** pipe orientation is correct.
- Check if the Unit is levelled.
- It is required to haunch the concrete under the tank to provide full support to the GRP case.

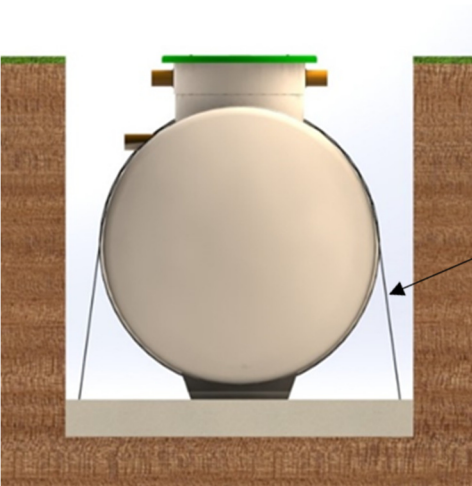

3. STRAP TANK TO CONCRETE BASE WHEN USING PEA GRAVEL

- **ONLY TO BE USED IN DRY SITE CONDITIONS**
- When using **Pea gravel or similar** as a backfill material **ONLY**
- Permanent ratchet strap should be at least 50mm wide, rated to 500kg.
- Pea Shingle - 6 mm to 10 mm rounded pea shingle, offering low point loading characteristics is the most suitable material for backfilling in dry ground installation.
- Make sure that voids are not left under and around the sides of the tank and that there are no localized stress concentrations.

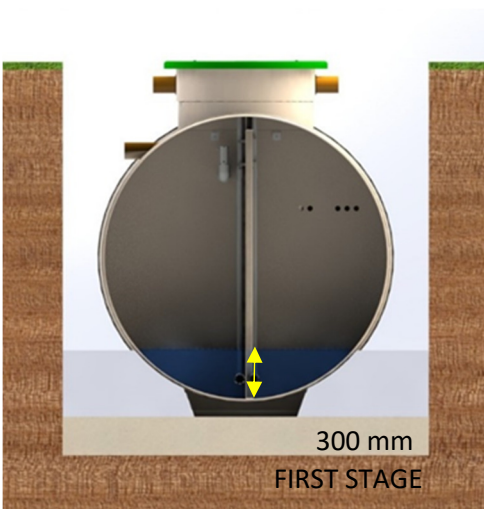

4. BACKFILL THE TANK UNIT

- The backfill should be free from organic material, large stones, brick or sharp objects.
- Backfilling should be carried out in layers, making sure that voids are not left under and around the sides of the tank and that there are no localized stress concentrations.
- It is most important that the installer progressively fills the tank with water to the level above the backfill to stabilize pressures on the tank.
- It is also important that the water level is always above or equal to the backfill level while backfilling the main body of the tank.

Make sure tank is ballasted with water in all chambers as you backfill.

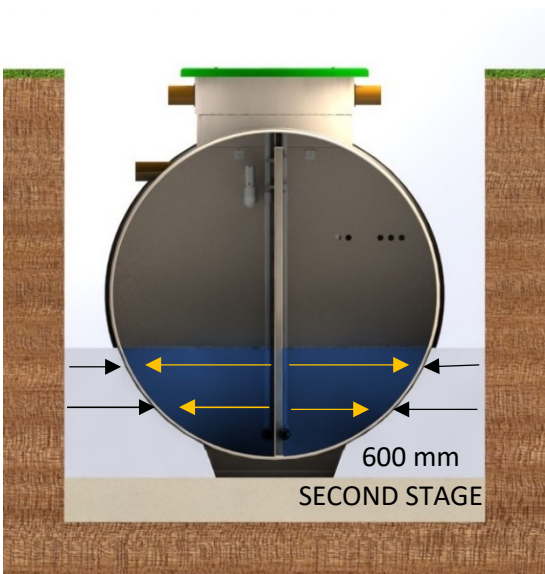
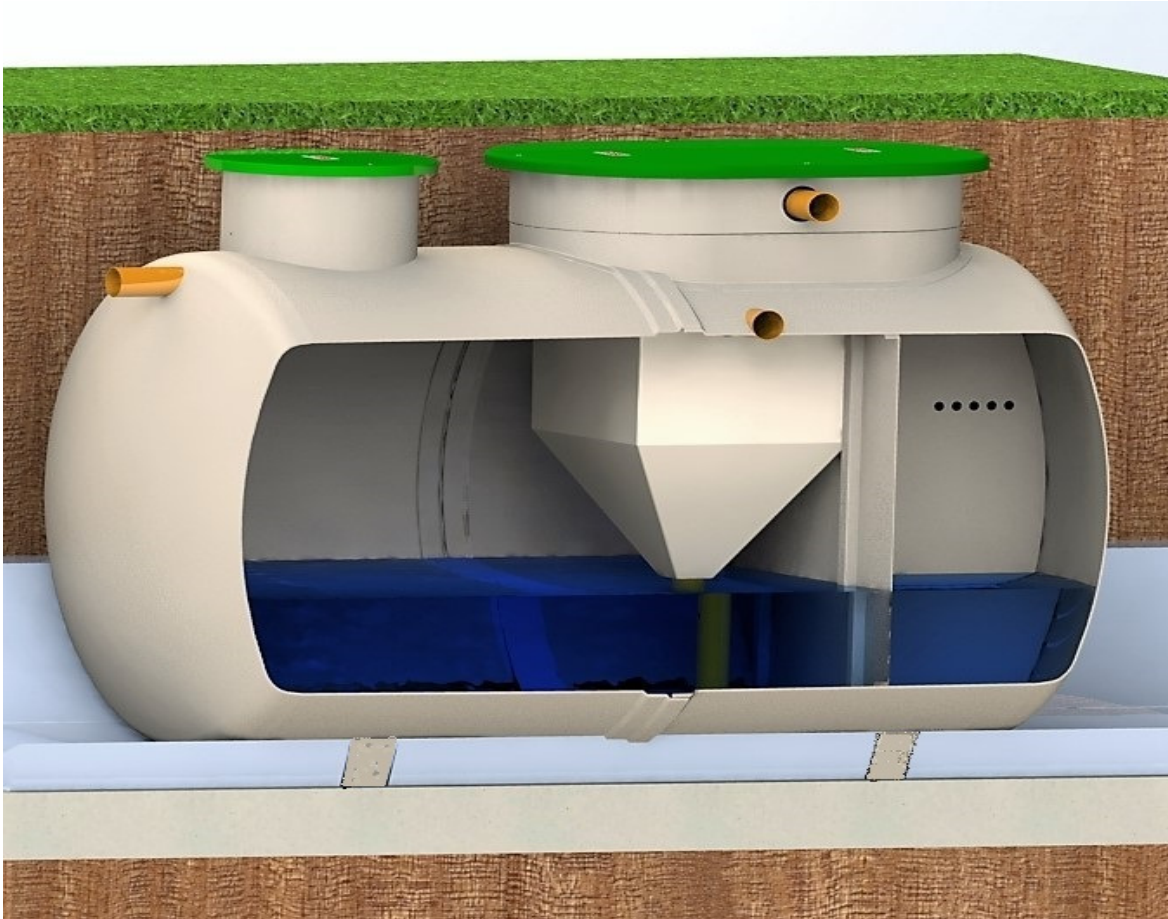

5. SECOND BACKFILL STAGE

- Ballast the tank with another 300mm of water in all chambers.
- Add same level of the backfill around the tank.
- It is most important that the installer progressively fills the tank with water to a level above the backfill to stabilise pressure on the tank.
- Backfill evenly all-round the tank, consolidating in layers. The backfilling should start before the base has hardened and be a single continuous operation so that the tank has a full concrete jacket without joins.

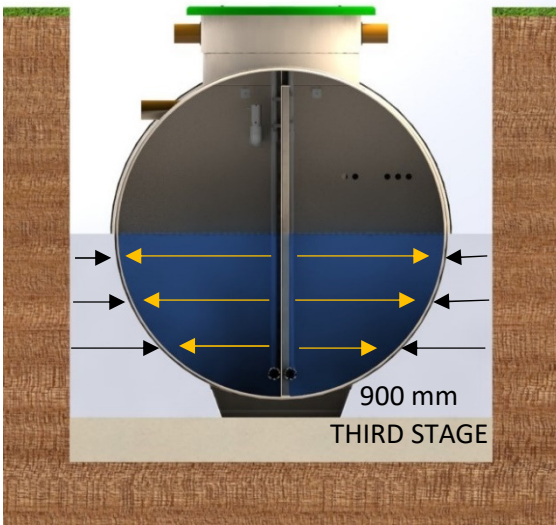

6. FURTHER BACKFILL STAGES

- Continue to fill up tank with water and backfill evenly all-around the tank, consolidating in 300mm layers.
- DO NOT use vibrating pokers to consolidate concrete.
- DO NOT discharge concrete directly on to the tank.
- Ensure that the concrete is not too wet and that is tamped in around the tank.
- Continue until just below inlet / outlet pipework.
- **Remove covers and connect inlet and outlet pipework.**
- Continue to backfill.

7. VENTING

- Installer must ensure adequate venting is provided for treatment plant to work efficiently.
- A vent connection is supplied in the tank neck and is clearly marked. This vent connection should only be used to connect to venting pipework.
- It is also important to seal off the air duct to the blower housing with expanding foam.
- This prevents odour from reaching the blower housing and ensures blower is only drawing in clean air.

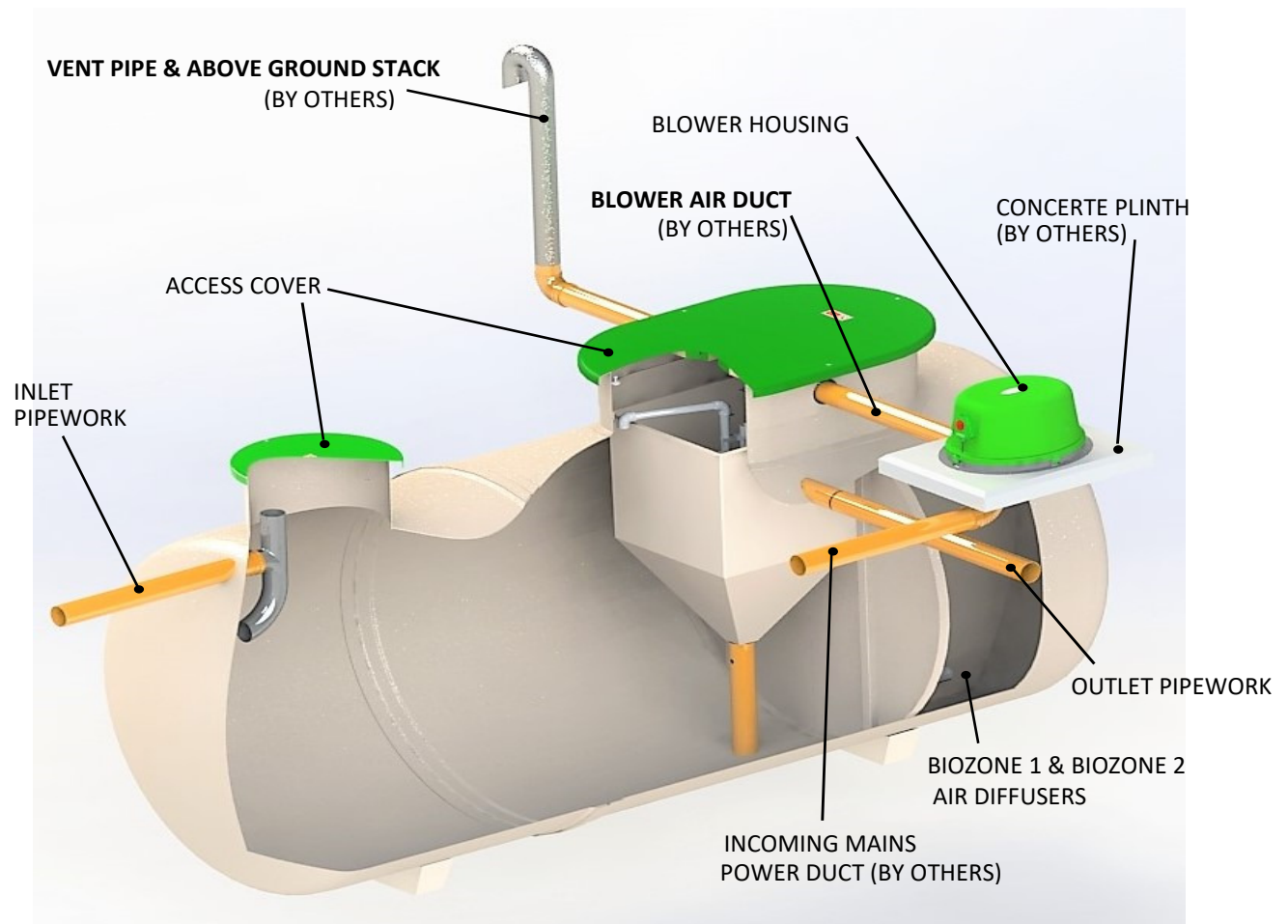

BioFicient® IPS HLA Installation

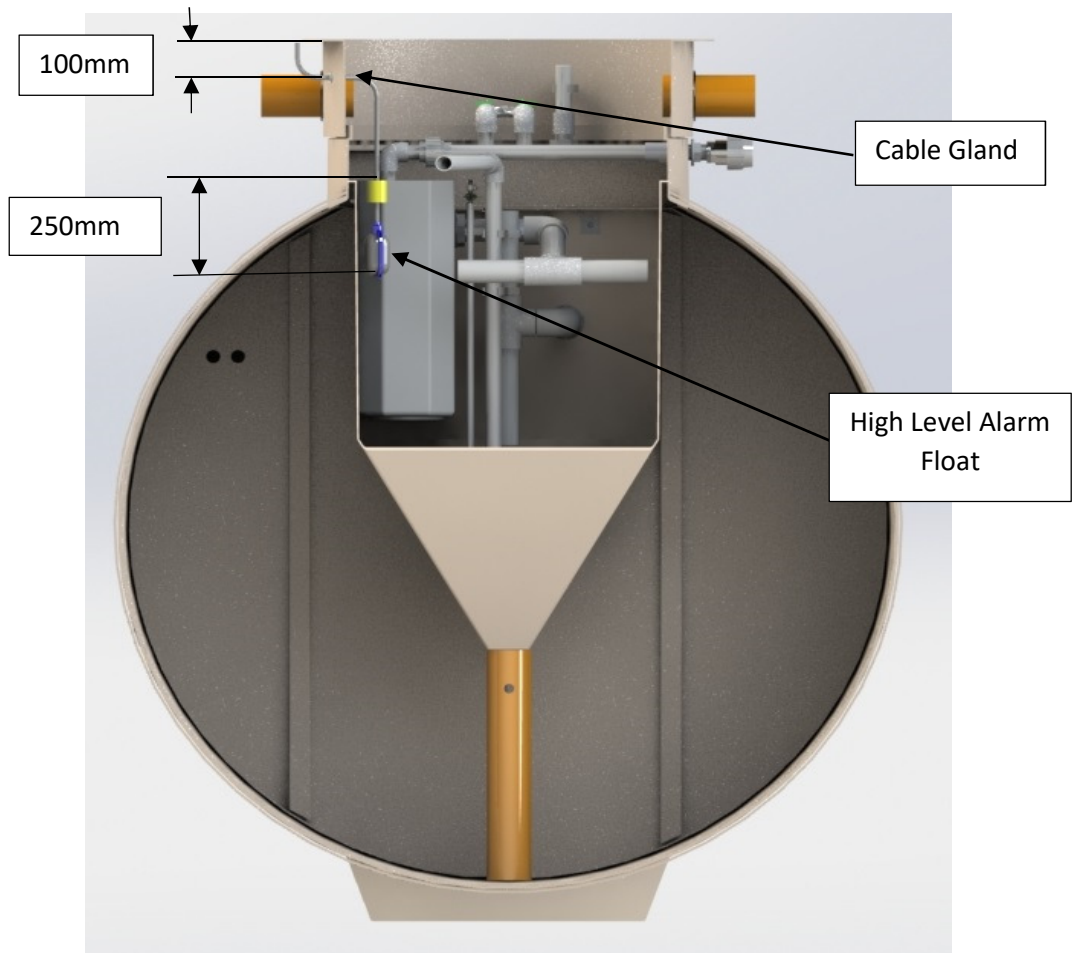

1. Remove the loose float, pivot weight & cable gland located in the blower housing.
2. Drill $\text{Ø}20\text{mm}$ hole & fit cable gland in position shown above the Final Settlement Tank (FST).
3. The bottom of the float to be approx. 250mm from the top of the pivot weight.
4. Pass the float cable through the cable gland and align the top of the pivot weight with the top of the FST. Tight the cable gland up.
5. Ensure the operation of the float will not foul on any pipework.
6. If required, float cable to be extended to control panel.
7. On All types of plant, connect hoses to Sludge Recycle and Diffusers.

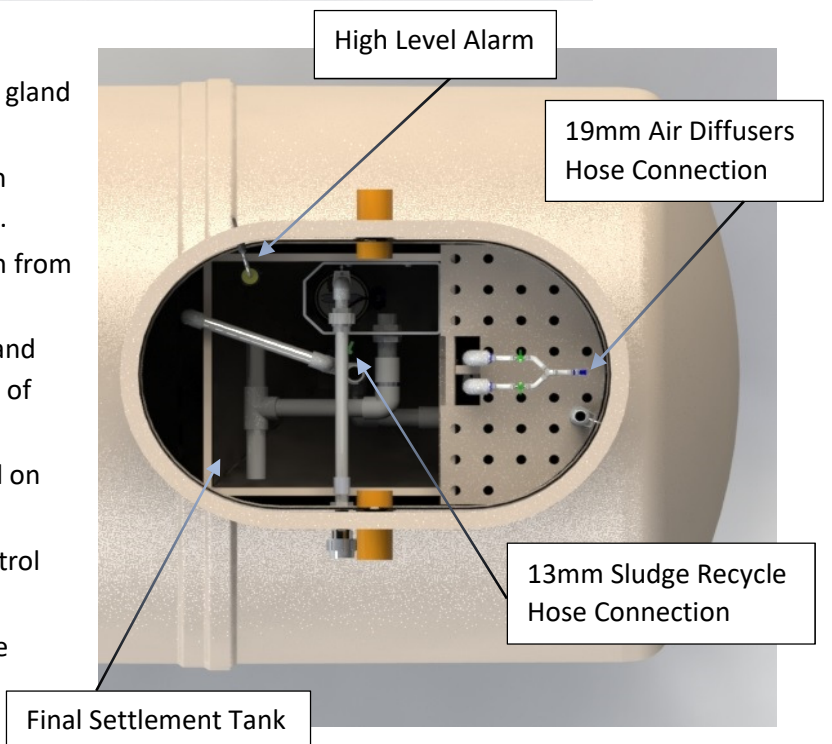

CONTROL PANEL INSTALLATION

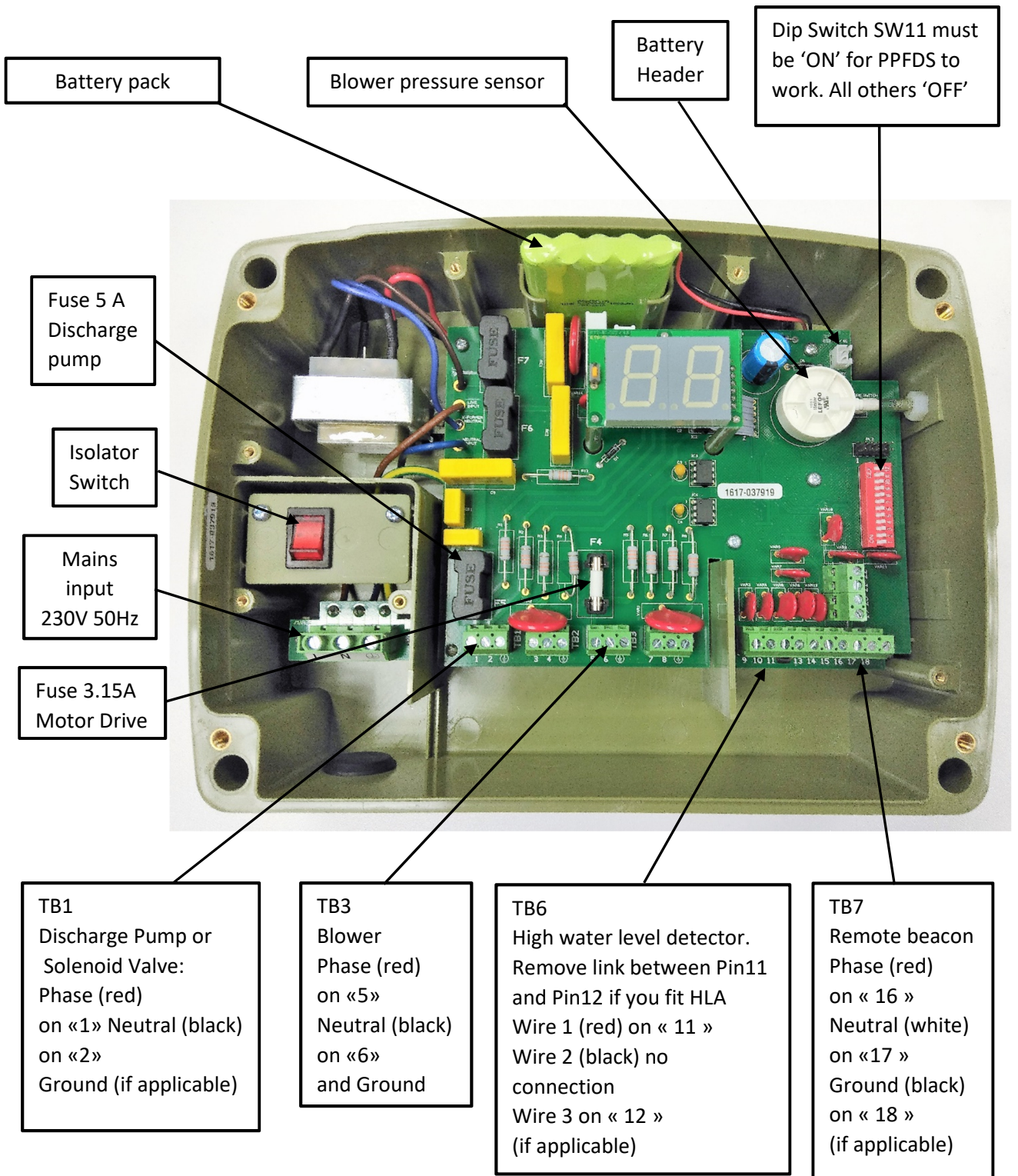

CONTROL PANEL ENTRY POINTS DEPENDING ON THE EQUIPMENT SUPPLY

* Pumped discharge only
 ** See Fig.1 below

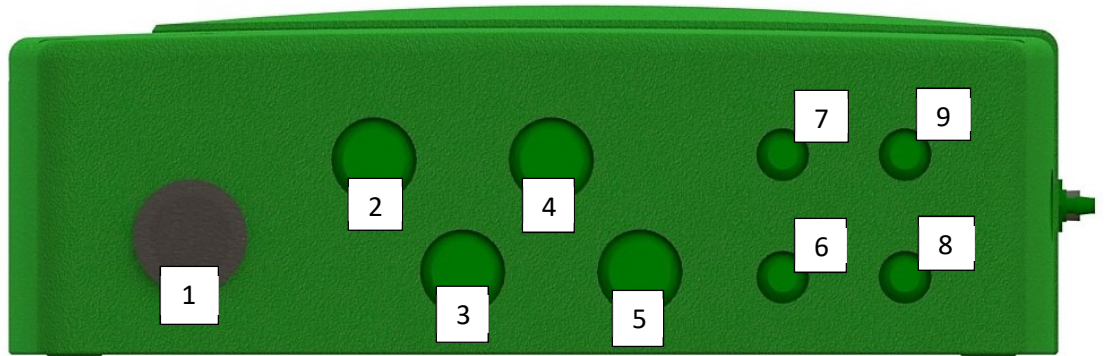

Product	Required Gland	Feed through Gland Hole number	Terminate to connection
Mains power supply	M20	1	
Integral discharge pump power cable	M20	2	1&2
Sludge Return Solenoid Cable *	M20	3	1&2
Blower power supply cable **	M20	4	5&6
High level alarm cable	M12	7	11&12
Beacon *	M12	9	16, 17&18

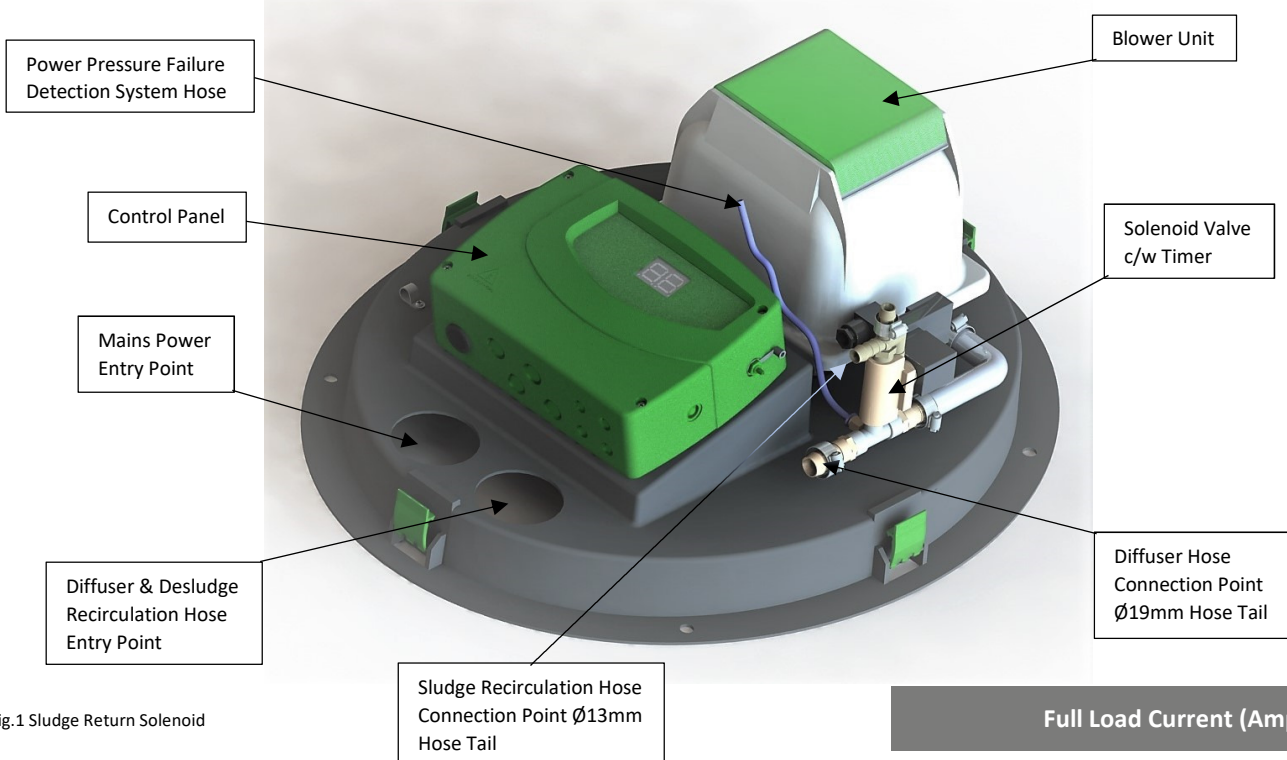
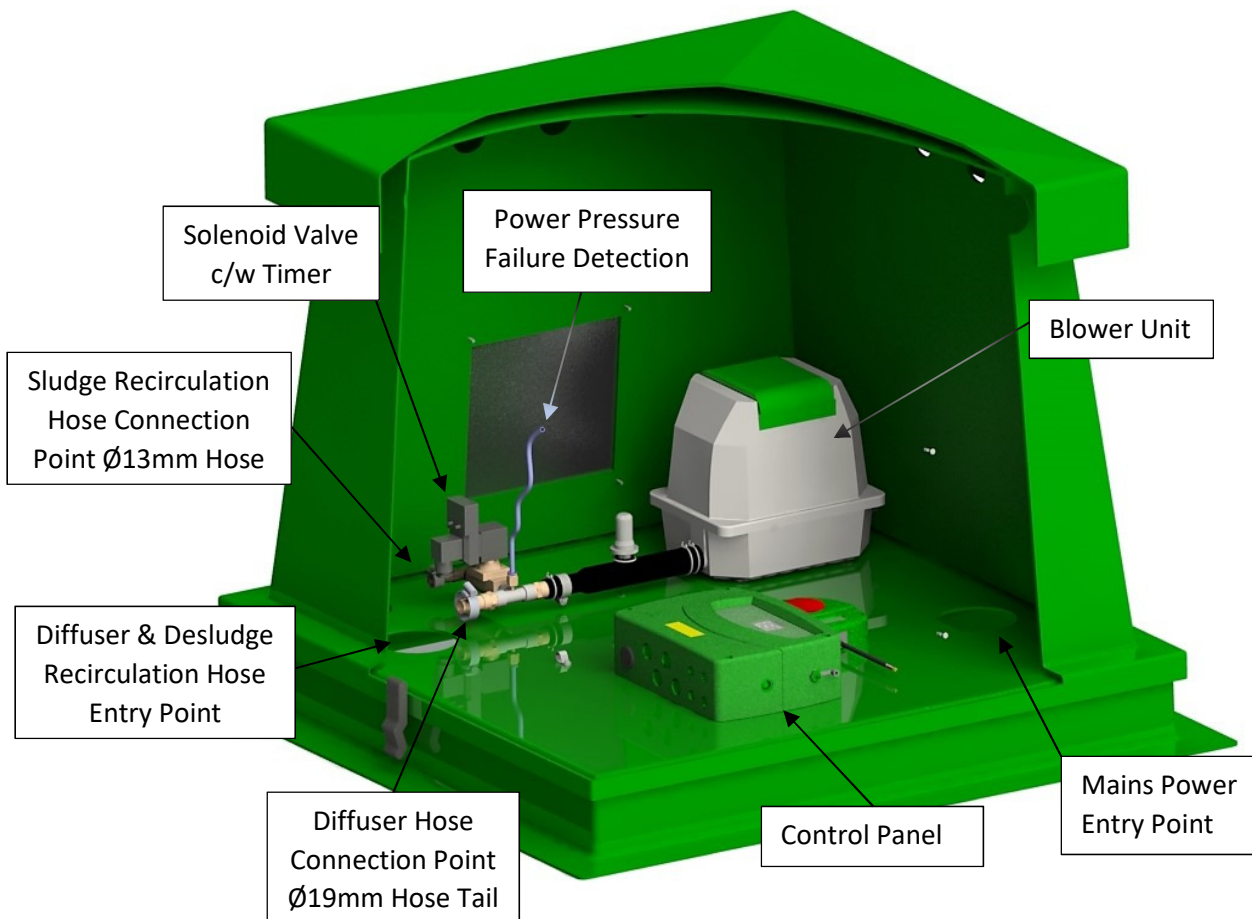

Fig.1 Sludge Return Solenoid

		Full Load Current (Amps)		
		Bioficient 4	Bioficient 5	Bioficient 6
Blower	240-volt single phase	0.7	1.0	1.4
Integral discharge pump	240-volt single phase only	2.2	2.2	2.2
Solenoid Valve	Low Voltage	0.08	0.08	0.08



SLUDGE RETURN SOLENOID RUN AND PAUSE TIME SETTING (IF FITTED)

1. When power is present, press "Mode" button until the display reads "on – off".
2. Press "Enter" button to accept mode selected.
3. To set "ON" time, press "Enter" button to move cursor along indicator to reach single minute's position.
4. Press "ADD" button to increment minutes.
5. Press "Enter" again to get to the end of display.
6. When display changes back to all zero's, timer is asking for "OFF" time.
7. Press "Enter" to get to single hour's section.
8. Press "ADD" to enter hours.
9. Press "Enter" again to get to the end of display.
10. When times have been entered, the "on – off" should appear for a few seconds and the timer will start working.
11. When timer is "ON" the indicator is illuminated.
12. Pressing "Reset" button in operation will cause the timer to re-start the "ON-OFF" cycle.
13. The timer should be factory set at the correct settings. (5 minutes "ON" and 1 hour "OFF")

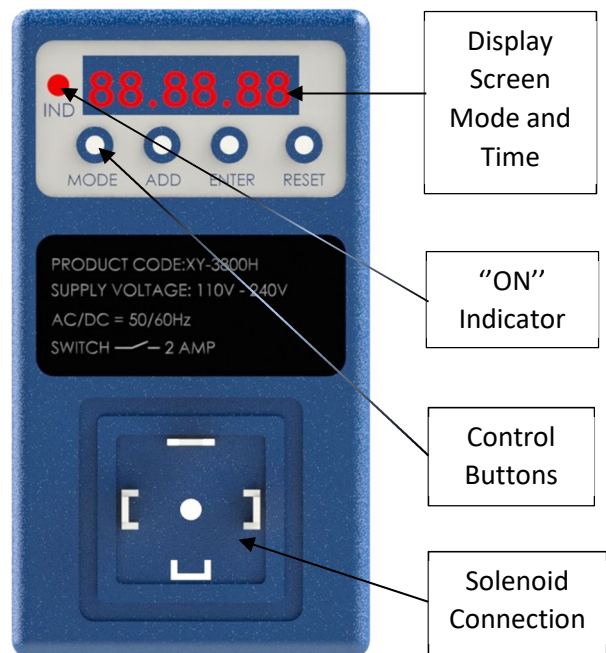

SLUDGE RETURN SOLENOID RUN AND PAUSE ANALOGUE TIMER SETTING (IF FITTED)

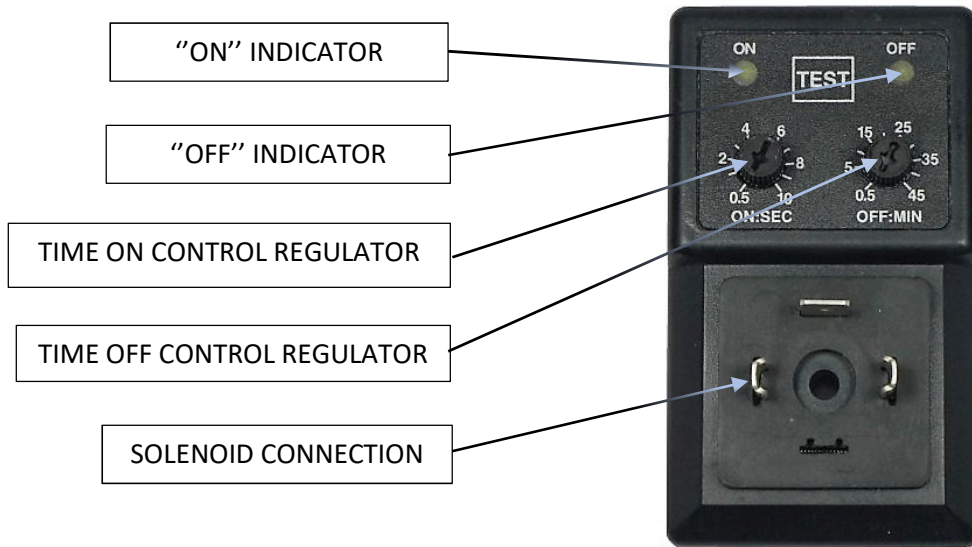

- The timer should be factory set at the correct settings.
- Factory settings are: 5 minutes for timer "ON" and 1 hour for timer "OFF".

COMPLETING THE INSTALLATION (refer to Control Panel illustration on page 13.).

1. Plug the lead from the battery into the small white socket in the top right corner of the PCB marked "BATTERY HEADER".
2. Power & Pressure Failure Detection System (where applicable) - Using a small screwdriver, push switch 11 to the ON position.
3. Installation of High Level Alarm (where applicable) - Remove the link in the terminal blocks between connections 11 & 12 (TB6) before inserting cables. Using a suitable M12 gland, feed the high-level alarm float cable through Gland Hole 7 and terminate to connection 11 & 12 (TB6) – Red to 11 & Black to 12.

CONTROL PANEL FAULT CODES AND FUSES

CODE	FAULT CONDITION	FUSE	Amp
F1	No power to the unit	Customer Fuse box	N/A
F2	The blower pressure has failed	N/A	N/A
F3	The high-level alarm has activated (where fitted)	N/A	N/A
F4	The fuse to the blower has failed	F4	3.15
F5	The fuse to the discharge pump has failed (where fitted)	F5	5.0
F6	The fuse to the chemical dosing pump has failed (where fitted)	F6	0.25
F7	The fuse to the recirculation pump has failed (where fitted)	F7	5.0
F8	The loss of rotation alarm has been activated (not applicable) The unit has had a fault which has now corrected itself	N/A	N/A
--	(Flashing left and right - Battery charging Flashing left only - Battery charged)	N/A	N/A

All fuses are Time Lag HBC 20mm type

START UP



We recommend that the unit has a Pre-Service Agreement Inspection by an approved engineer.



Once the unit has been installed it should be left filled with water.

NOTES



Kingspan Environmental Ltd

Unit 1, Derryboy Road
Carnbane Industrial Estate
Newry

BT35 6QH

GB T: 084 48 46 0500

NI T: 028 30 25 4077

IRL T: 048 30 25 4077

www.kingspan.ie/klargester

Kingspan Environmental

College Rd North
Aston Clinton, Aylesbury
HP22 5EW

T: 01296633000

After-sales Service & Support

T: 0333 240 6868

E: helpingyou@kingspan.co.uk